

Net weight: 59,00 kg  
 Gross weight: 94,00 kg  
 Volume: 0 m<sup>3</sup>

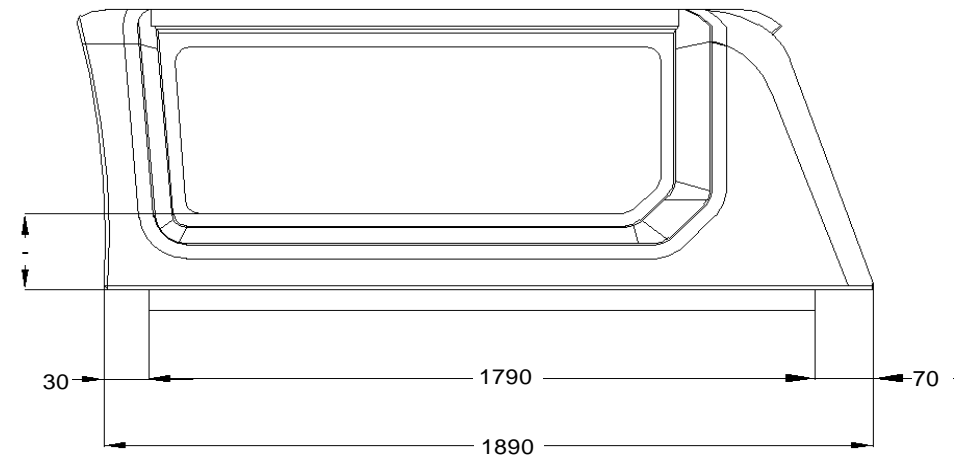

7 X 30 X 10000 A/60/PT3 PE-L - 4 m  
 20 x 10 x 5000 GKS ECONOMY - 1,65 m

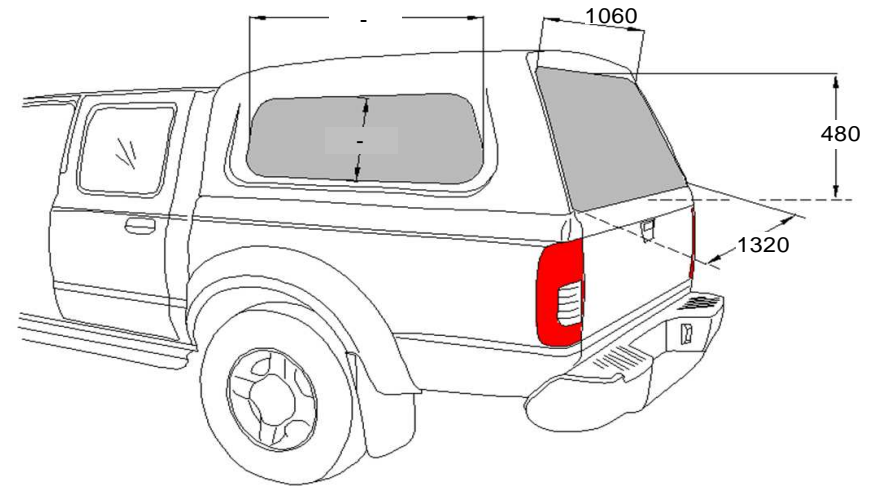
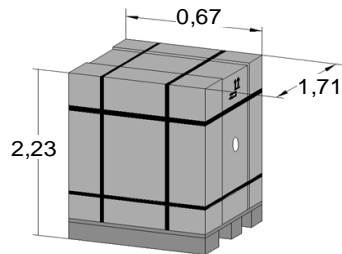
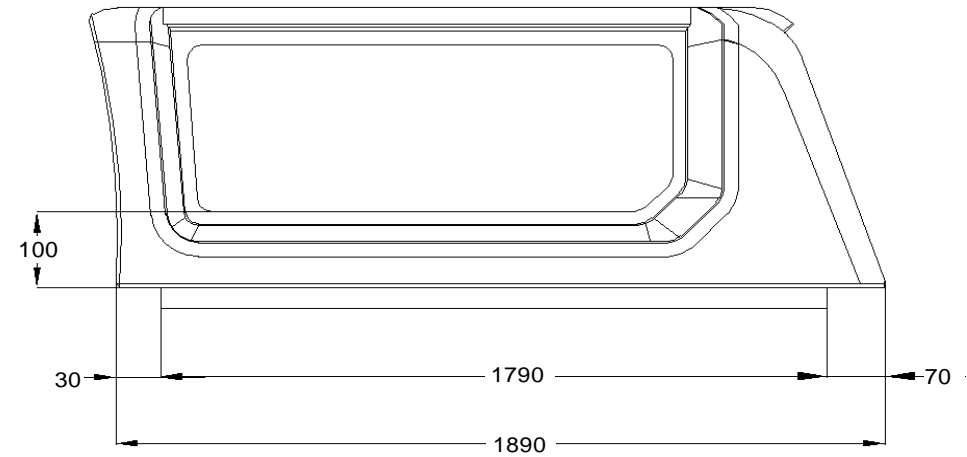
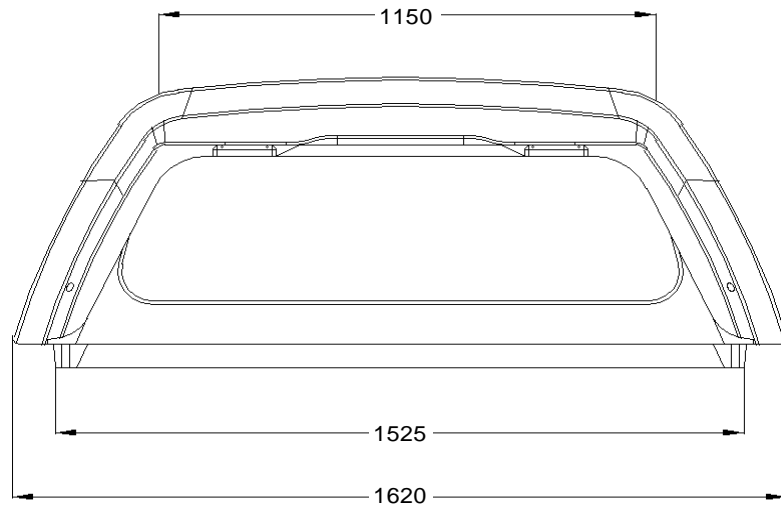
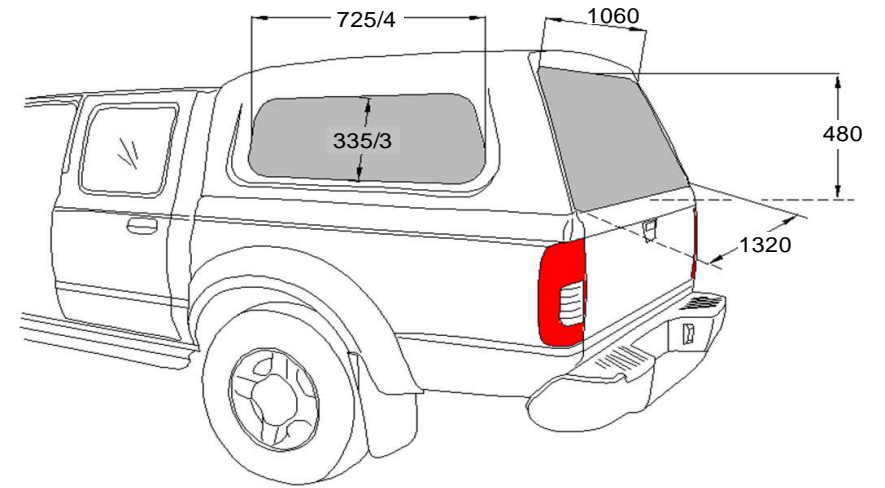
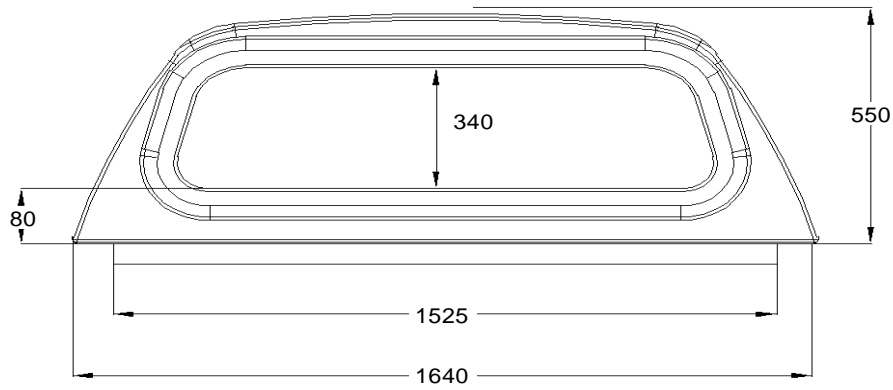

Net weight: 76,00 kg  
 Gross weight: 111,00 kg  
 Volume: 0 m<sup>3</sup>

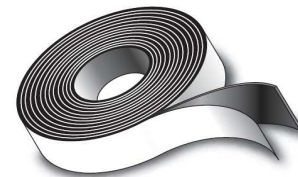

7 X 30 X 10000 A/60/PT3 PE-L - 5 m  
 20 x 10 x 5000 GKS ECONOMY - 3 m

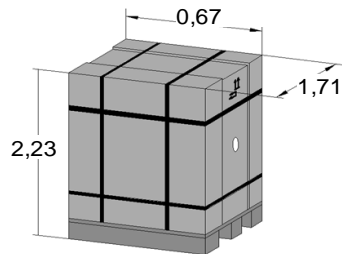
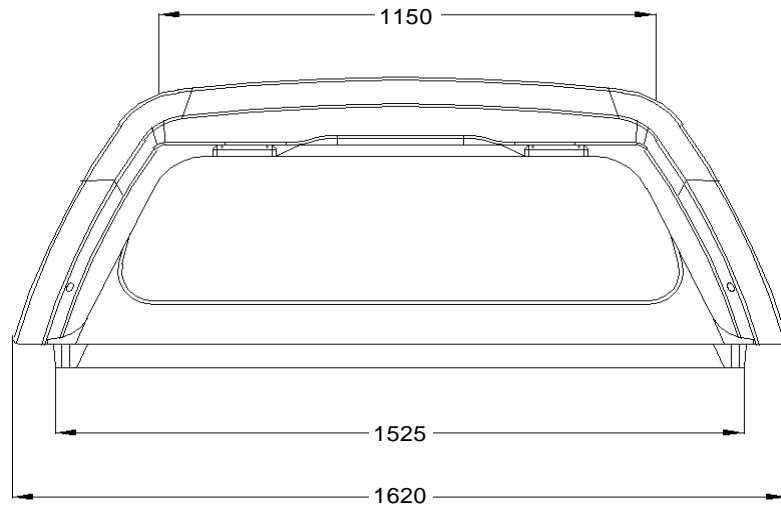
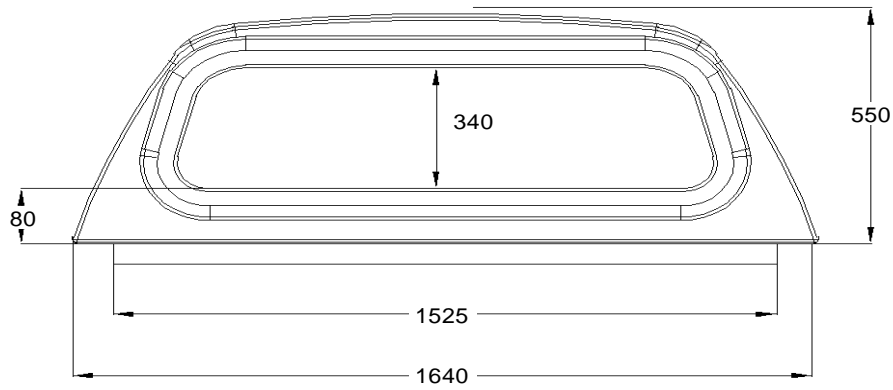

Net weight: 82,00 kg  
 Gross weight: 117,00 kg  
 Volume: 0 m<sup>3</sup>

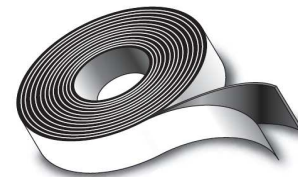
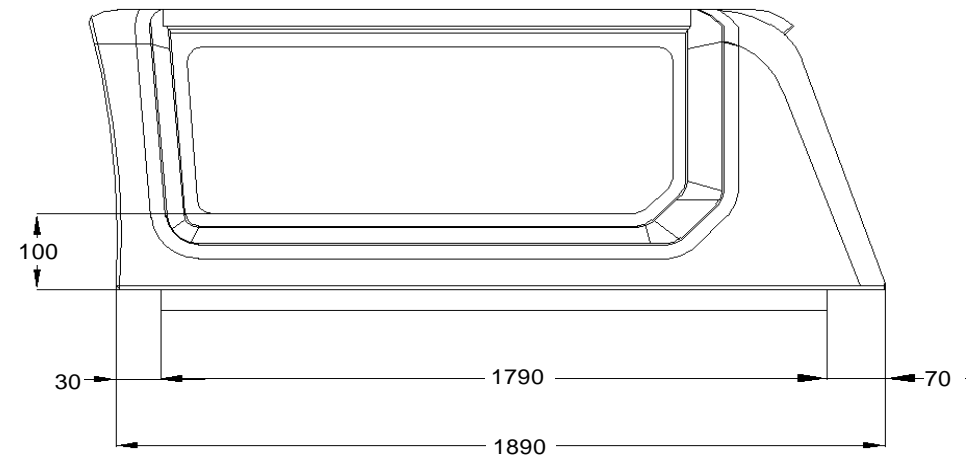
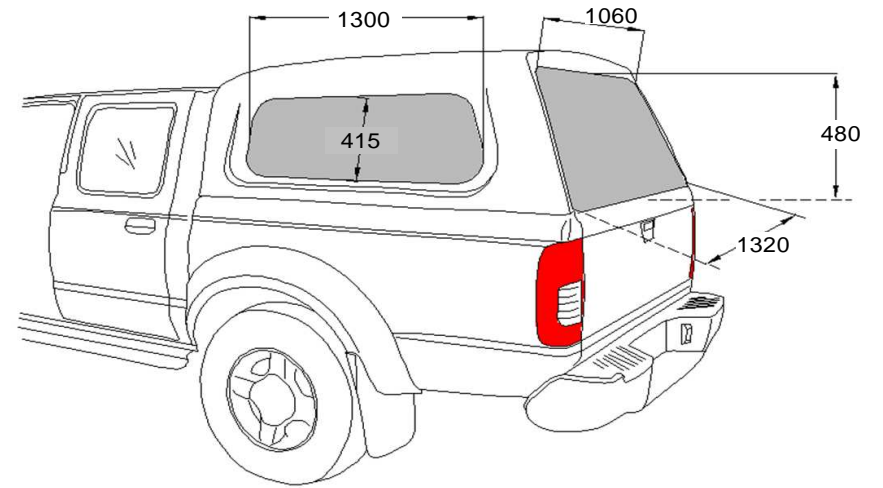

7 X 30 X 10000 A/60/PT3 PE-L - 4 m  
 20 x 10 x 5000 GKS ECONOMY - 1,65 m