

# Geschlossen / Closed

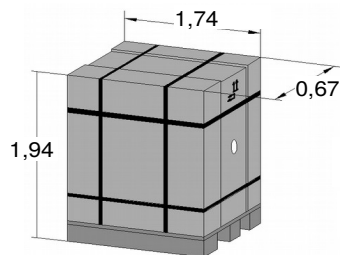

IS DC RH04 IF S LAK - 1900988

Wymiary nadbudowy samochodowej - Dimensions of hardtop

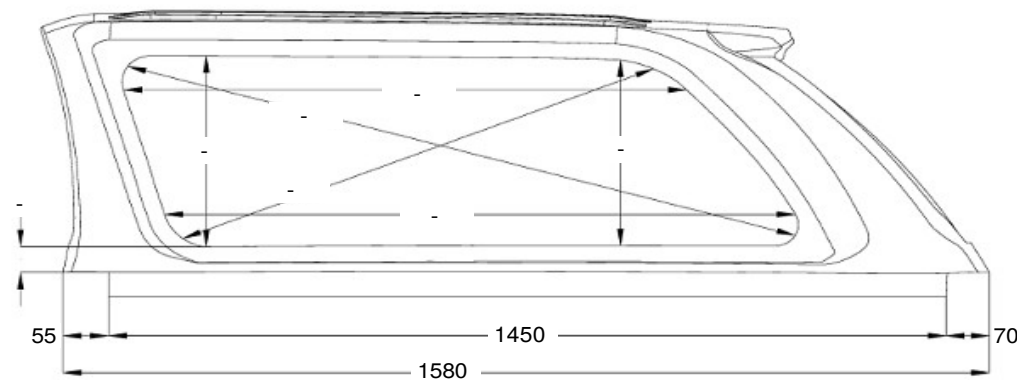
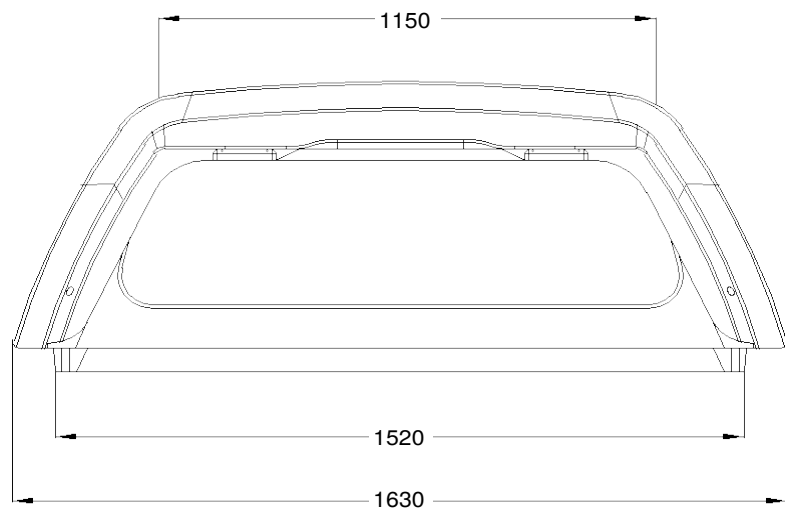
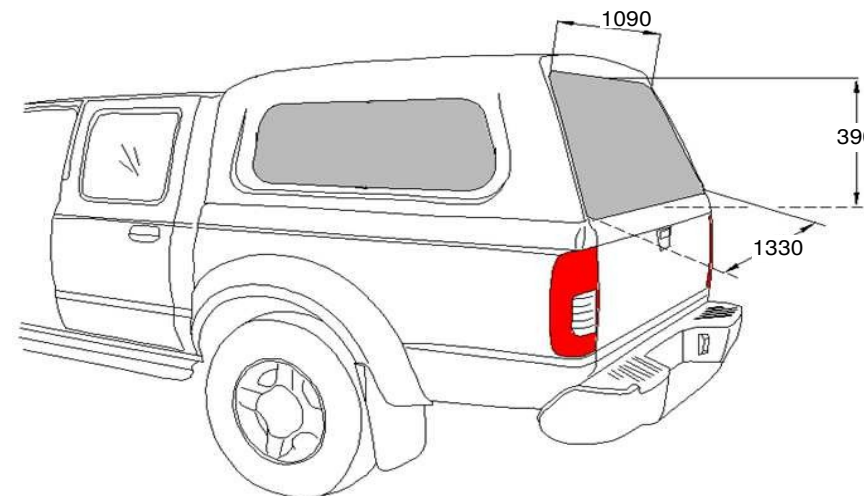
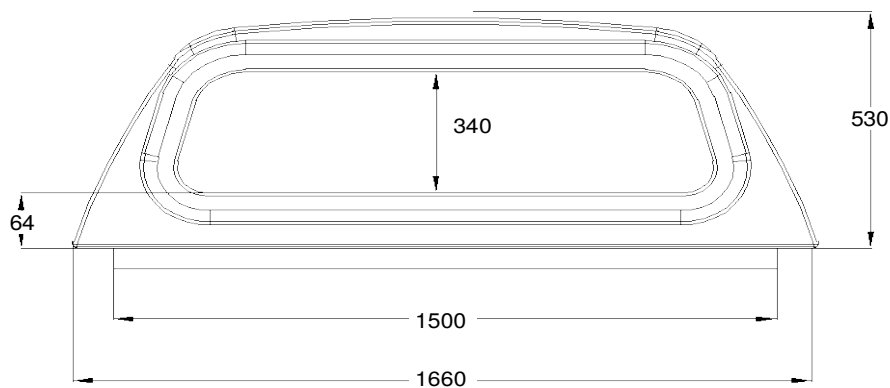

Net weight: ,00 kg  
 Gross weight: ,00 kg  
 Volume: 2,26 m3

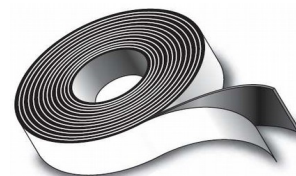

20 x 10 x 5000 GKS ECONOMY - 1,65 m  
 7 X 30 X 10000 A/60/PT3 PE-L - 3,3 m

## Geschlossene Fenster / Closed Windows

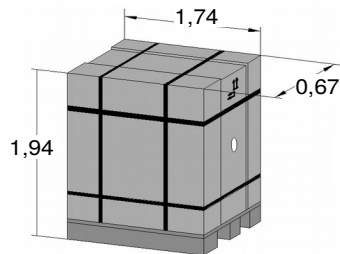
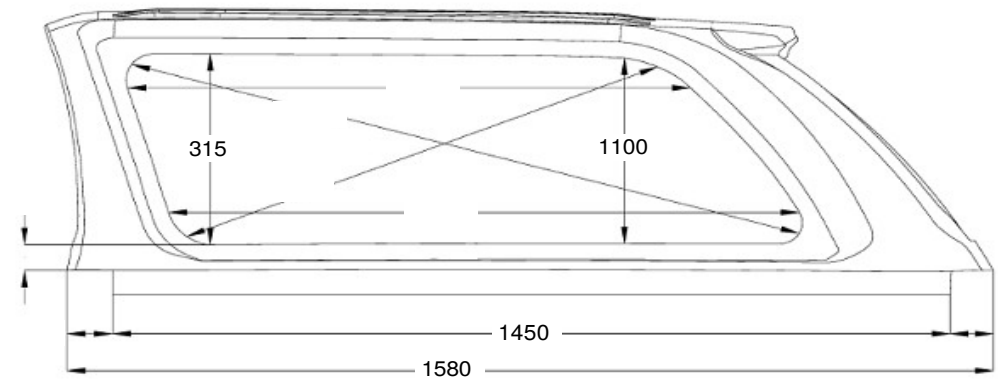
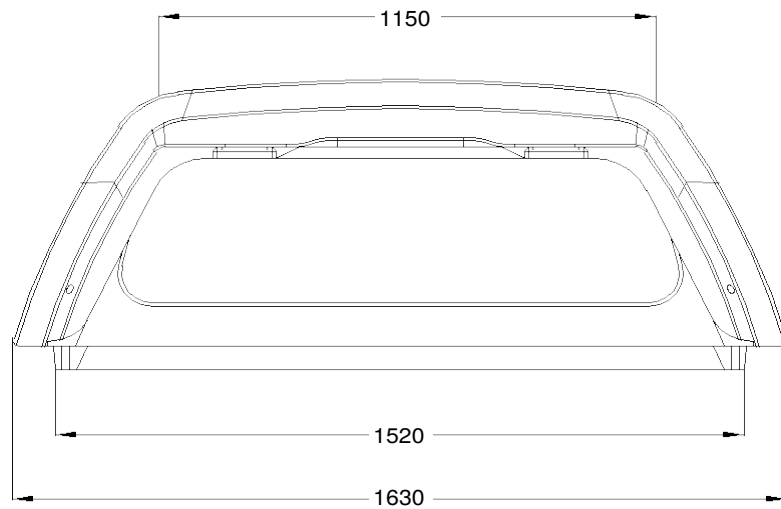
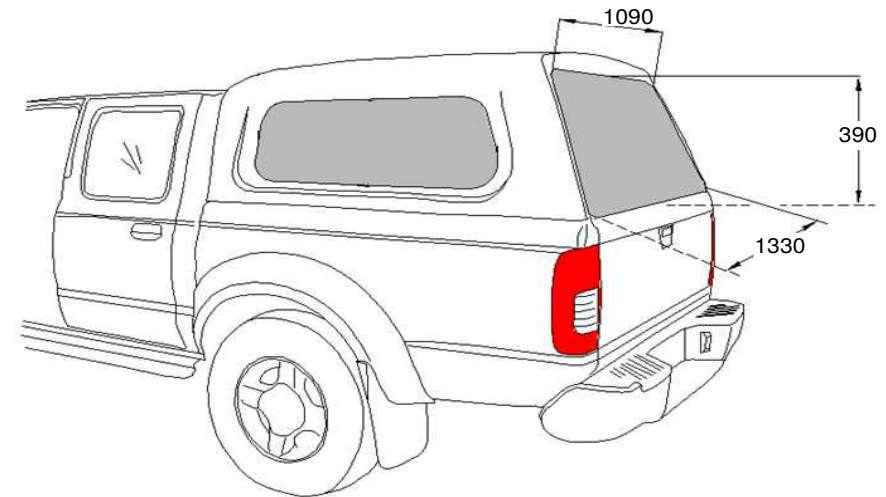
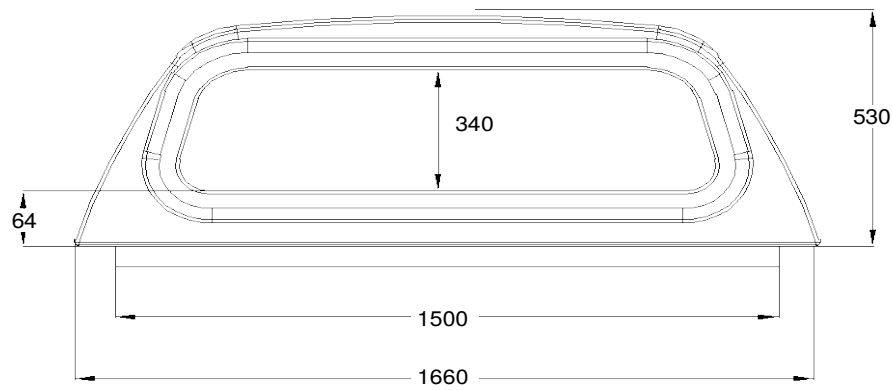

Net weight: 69,00 kg  
 Gross weight: 99,00 kg  
 Volume: 2,26 m<sup>3</sup>

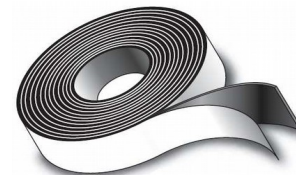

20 x 10 x 5000 GKS ECONOMY - 1,65 m  
 7 X 30 X 10000 A/60/PT3 PE-L - 3,3 m

IS DC RH04 IF F LAK - 1900989  
 Wymiary nadbudowy samochodowej - Dimensions of hardtop

## Kunststoffseitenklappen / Plastic side flaps

IS DC RH04 IF S2 LAK - 1900991

Wymiary nadbudowy samochodowej - Dimensions of hardtop

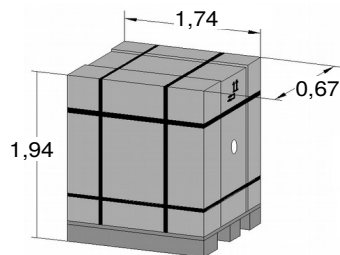
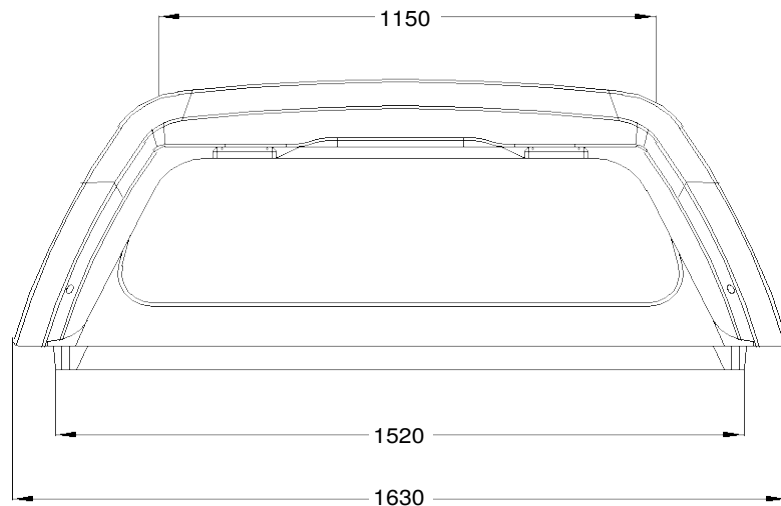
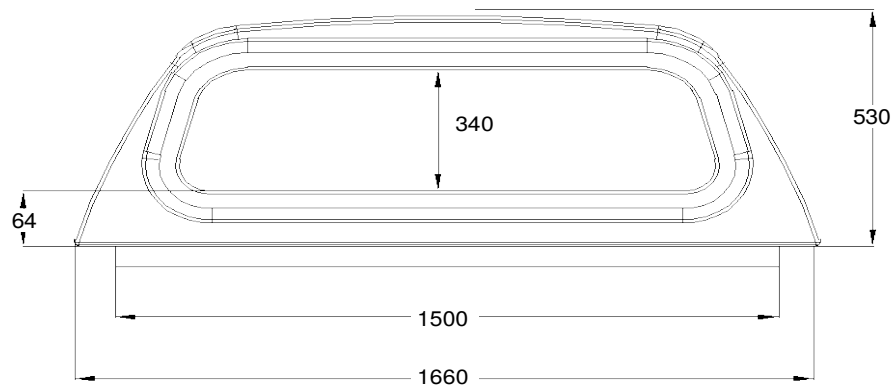

Net weight: 75,00 kg  
 Gross weight: 99,00 kg  
 Volume: 2,26 m<sup>3</sup>

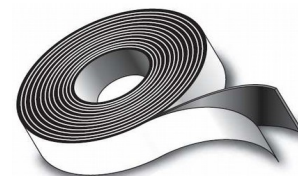
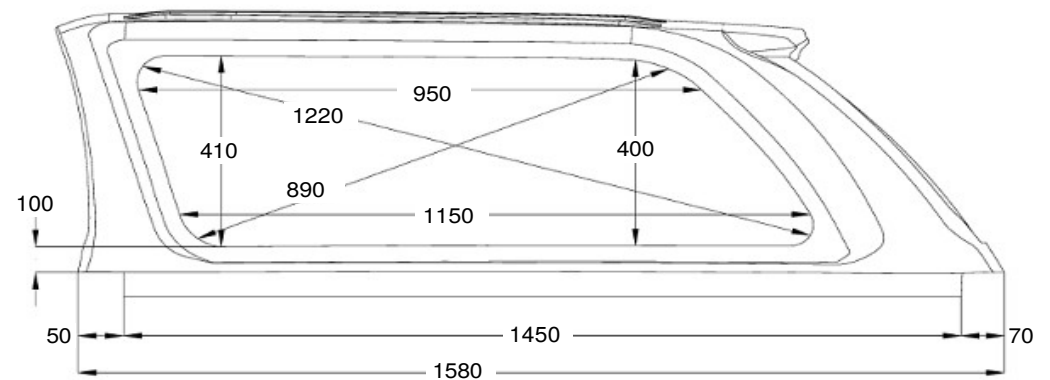
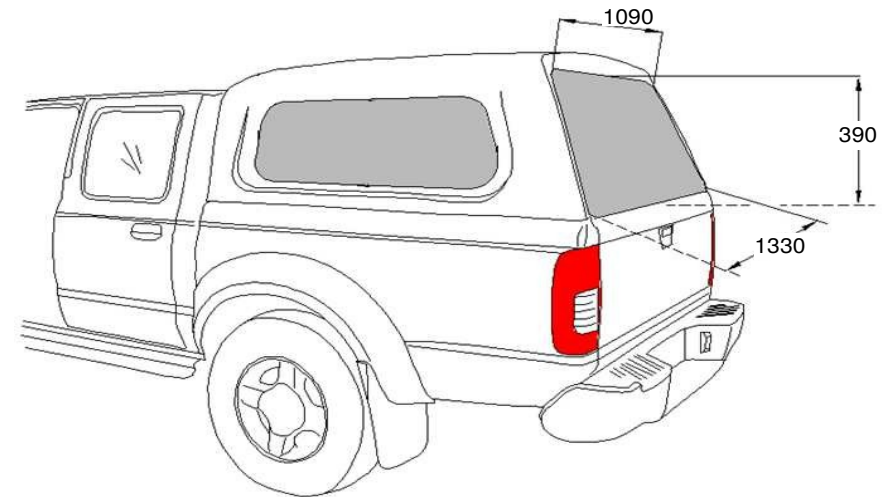

20 x 10 x 5000 GKS ECONOMY - 1,65 m  
 7 X 30 X 10000 A/60/PT3 PE-L - 3,3 m

## Glasseitenklappen / Glas side flaps

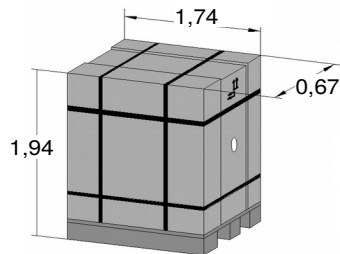
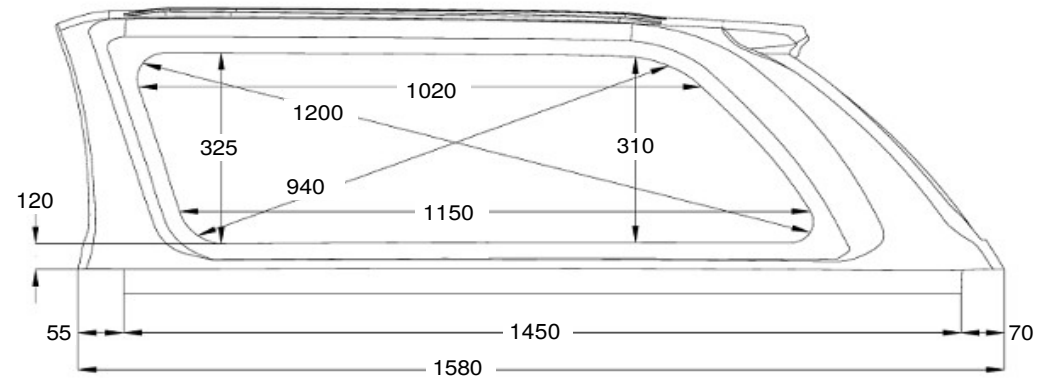
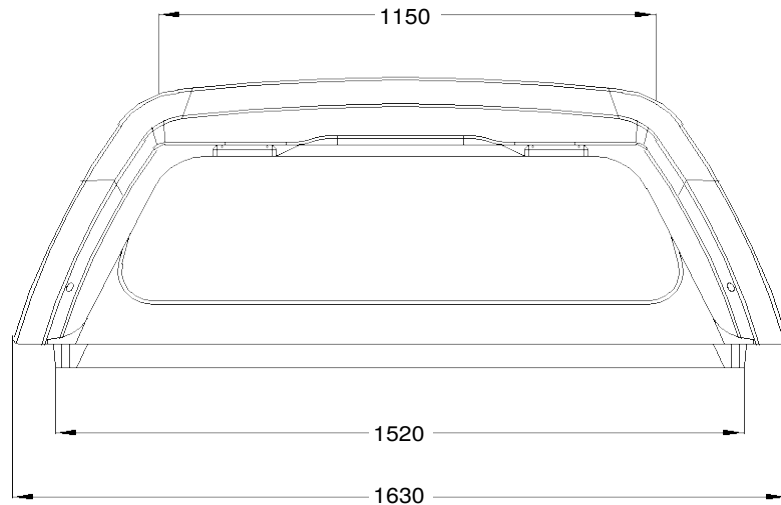
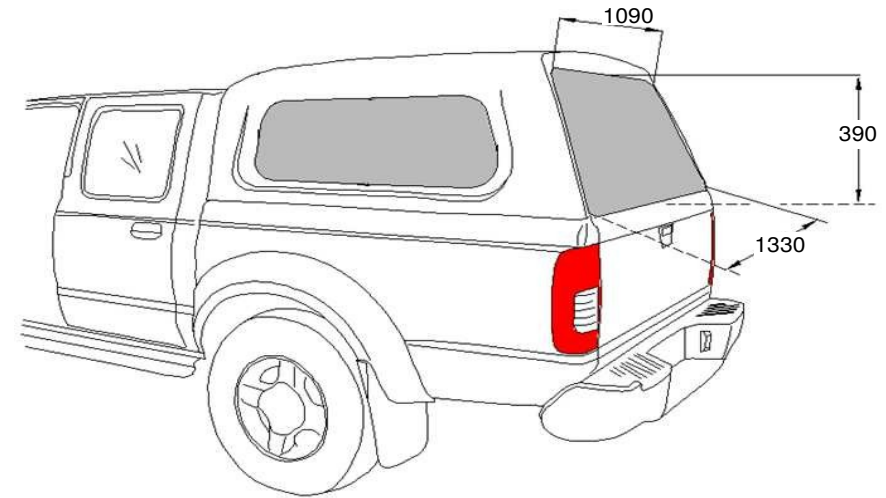
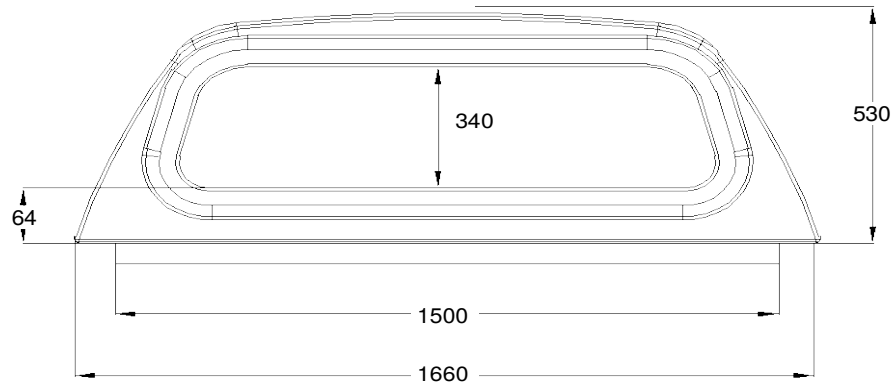

Net weight: 85,00 kg  
Gross weight: 115,00 kg  
Volume: 2,26 m3

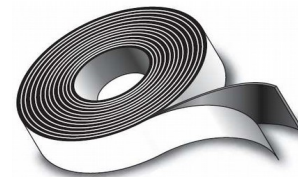

20 x 10 x 5000 GKS ECONOMY - 1,65 m  
7 X 30 X 10000 A/60/PT3 PE-L - 3,3 m

IS DC RH04 IF FS2 LAK - 1900990  
Wymiary nadbudowy samochodowej - Dimensions of hardtop