

SSANG YONG
SY DC RH01 3 F2 LAK (1900725)

RU Внимательно прочитайте данную инструкцию, до того, как начнете установку. Гарантийные обязательства выполняются только при условии произведения установки на СТО Вашего официального дилера. Инструкция описывает установку различных моделей хардтопов. Рисунки хардтопов представленные в данной инструкции могут отличаться от внешнего вида Вашей модели.

D Bitte sehen Sie diese Einbau-Anleitung gründlich durch, bevor Sie mit der Montage anfangen. Garantie wird nur gewährt, wenn die Montage von einer Fach-werkstatt ausgeführt worden ist. Änderungen hinsichtlich Ausstattung, Konstruktion, Abbildungen und Text vorbehalten.

GB Read this mounting manual carefully, before you start the installation. Warranty is guaranteed only when installation is done by your dealer's garage. Modification related to design, construction, illustrations and text are reserved.

F Lisez cette notice de montage soigneusement avant l'illustration. Une garantie est seulement délivrée si l'installation a été exécuté par un commerçant. Sous réserve de modifications de projet, construction, illustrations et texte.

H Szerelés előtt alaposan tekintse át a szerelési útmutatót. Garanciát csak abban az esetben vállalunk, ha a felépítmény felhelyezése szakmühelyben történik. A változtatás jogát a külső, a szerkezet, a képek és a szöveg terén fenntartjuk!

P Leia este manual de montagem cuidadosamente, antes de iniciar a instalação. A garantia só é considerada apenas quando a montagem for efectuada por uma oficina especializada. Com reserva de modificações relacionadas com design, construção, ilustrações e texto.

I Si prega di prendere attentamente visione delle presenti istruzioni di montaggio prima di procedere all'installazione dell'hardtop. La garanzia è valida solamente se il montaggio è stato eseguito da un'officina autorizzata. Con riserva di modifiche relative alla dotazione, costruzione, immagini e testo.

E Lea por tanto con atención este manual (folleto) antes de que la instalación comienza. Garantía es válida solamente si la instalación de este producto fue instalada por medio de una distribuidora autorizada. Cambios en proyecto, construcción, retrato y texto son prohibidos.

S Läs noggrant igenom denna monteringsanvisning innan du börjar Installationsarbetet. Garantin gäller endast då installationen är utförd av en auktoriserad verkstad eller är fackmannamässigt utförd. Med reservation för modifieringar gällande design, konstruktion, illustrationer och text.

PL Prosimy zapoznać się z instrukcją przed rozpoczęciem instalacji nadbudowy. Gwarancja zostanie uznana tylko wtedy gdy instalacja zostanie wykonana przez autoryzowanego dealera. Jakakolwiek zmiana wyglądu, konstrukcji, ilustracji lub tekstu jest zabroniona.

Montageanleitung >> Инструкция по установке >> >

Installation instruction >> Istruzioni di montaggio >> Instrucciones de montaje >> Montageanvisning >> Instruções de Montagem

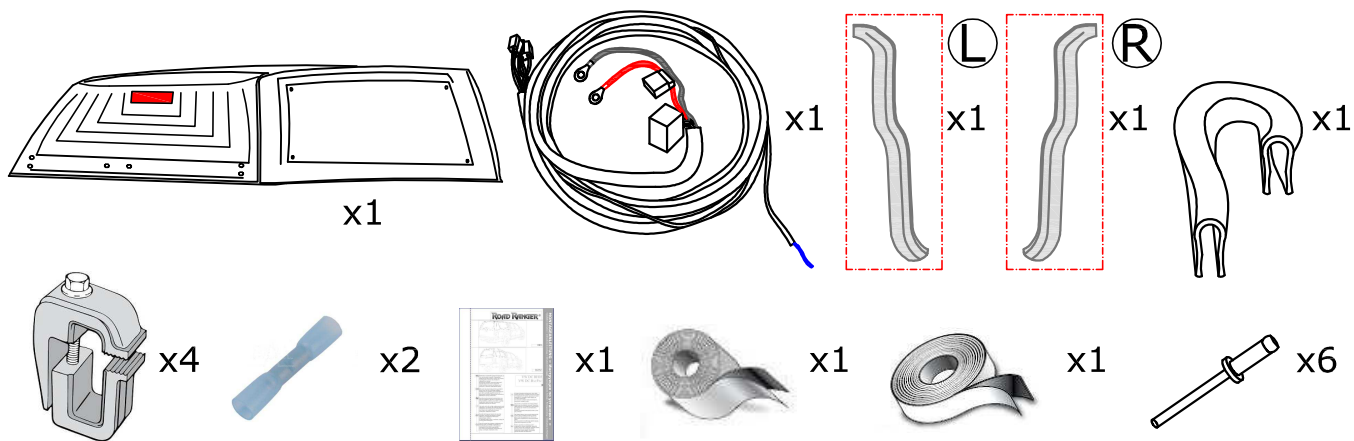

1.

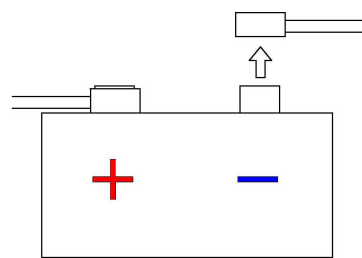
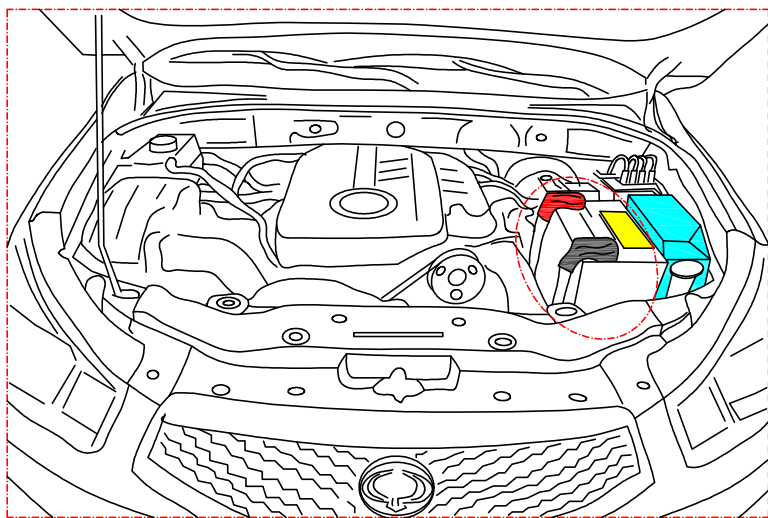

2.

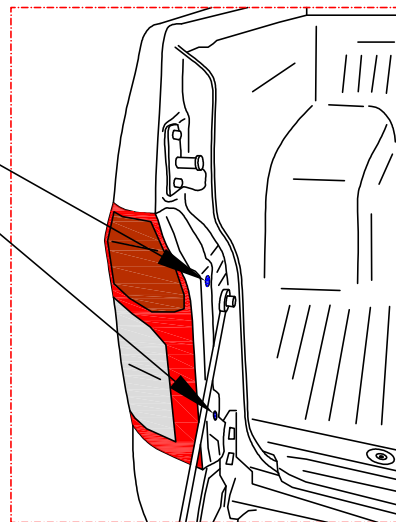
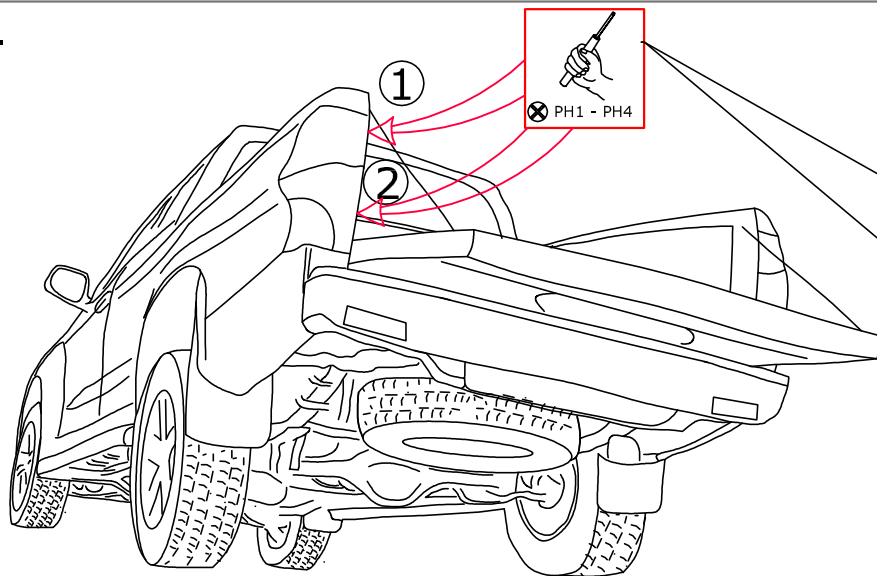

3.

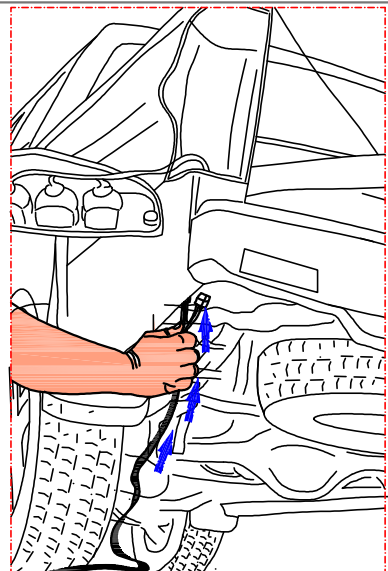
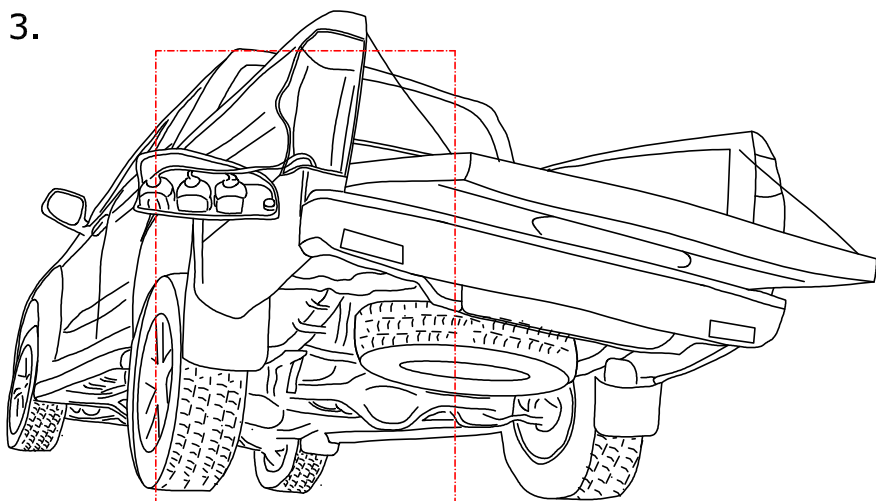

4.

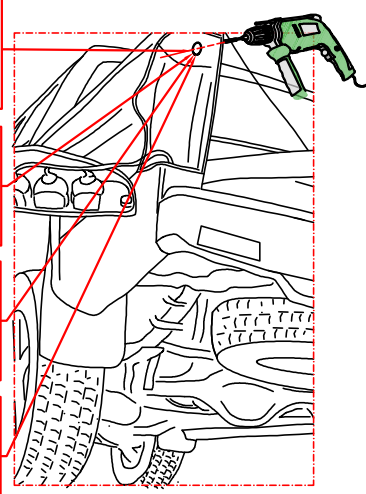
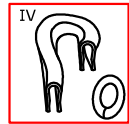
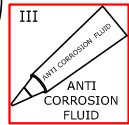
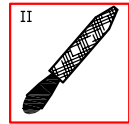
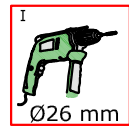
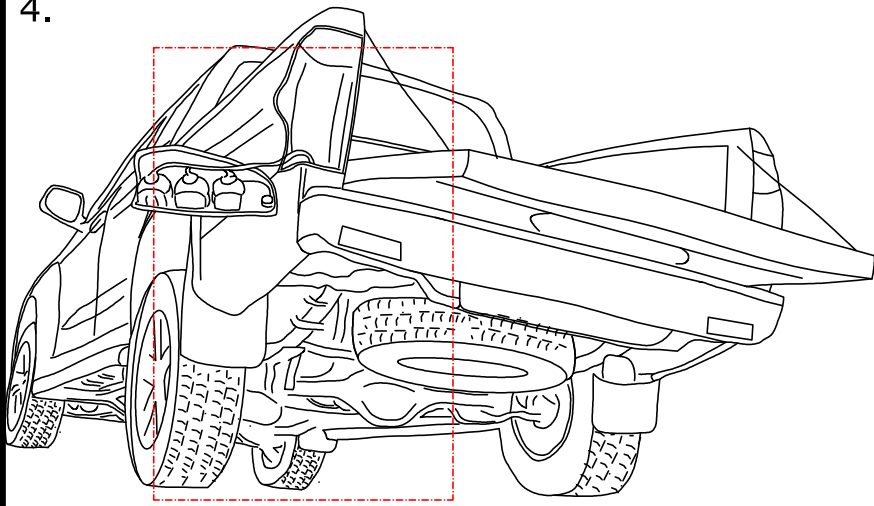

5.

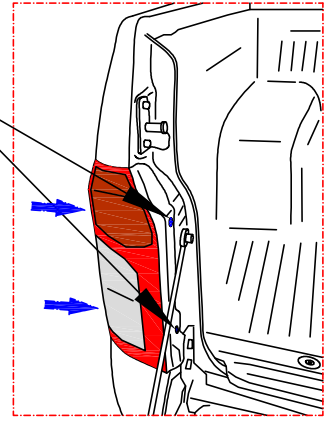
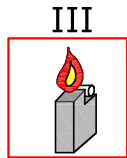
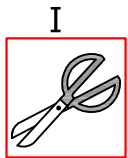
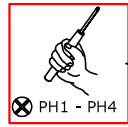
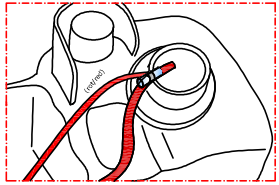
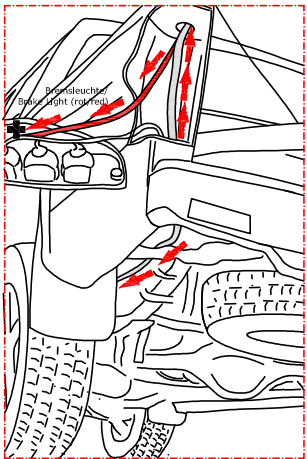

6.

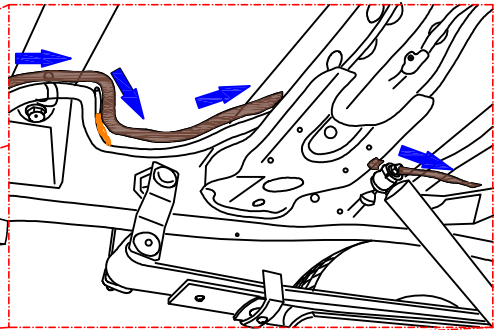
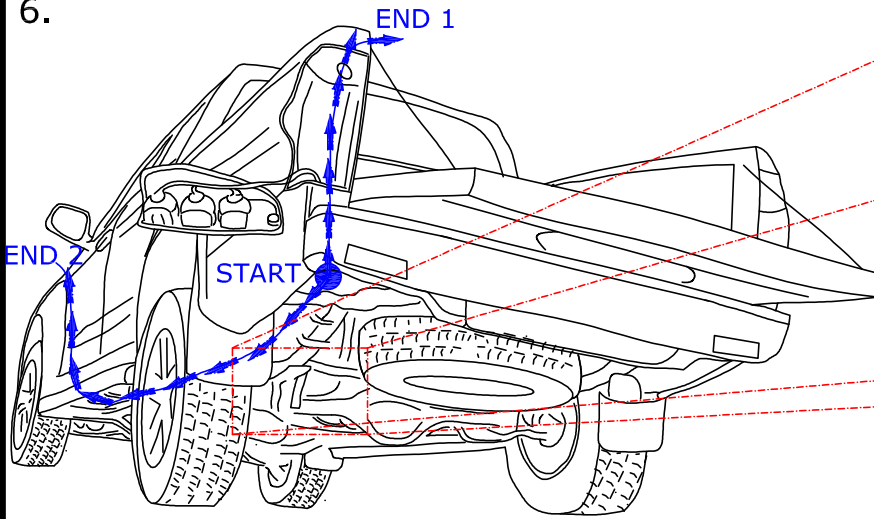

7.

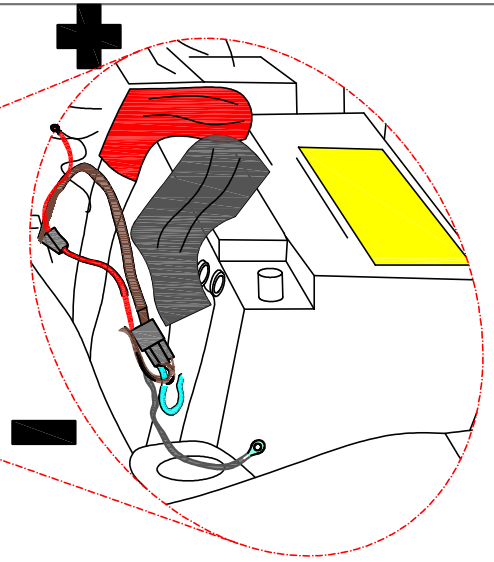
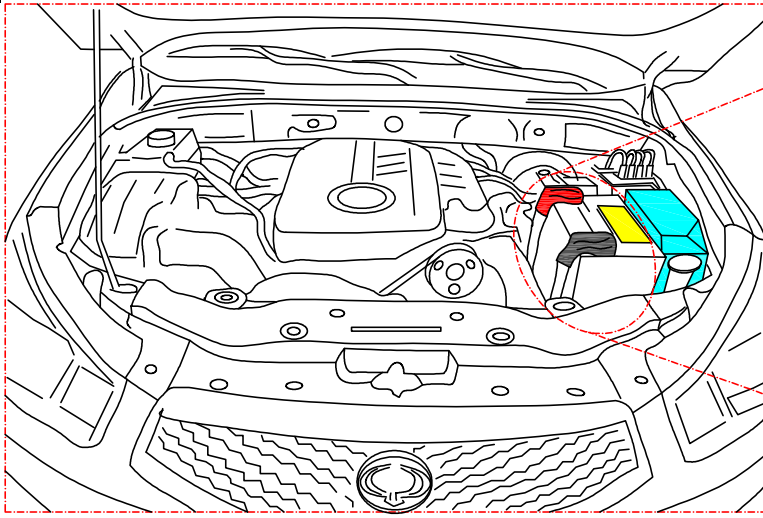

Montageanleitung >> Инструкция по установке >> >

Installation instruction >> Instrucciones de montaje >> Istruzioni di montaggio >> Montageanvising >> Instruções de Montagem

Montageanleitung >> Инструкция по установке >>

Installation instruction >> Istruzioni di montaggio >> Instrucciones de montaje >> Montageanleitung >> Montagevisning >> Instruções de Montagem

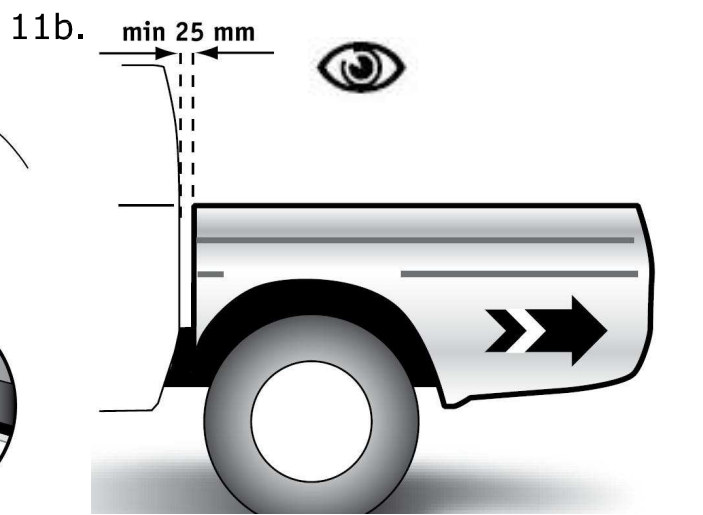
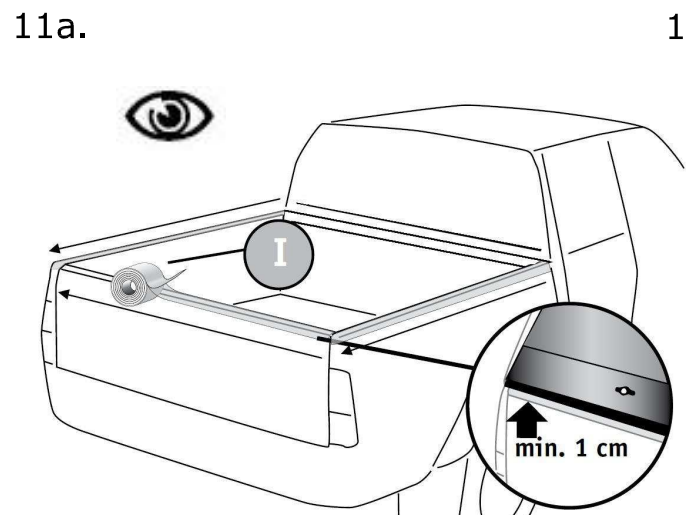
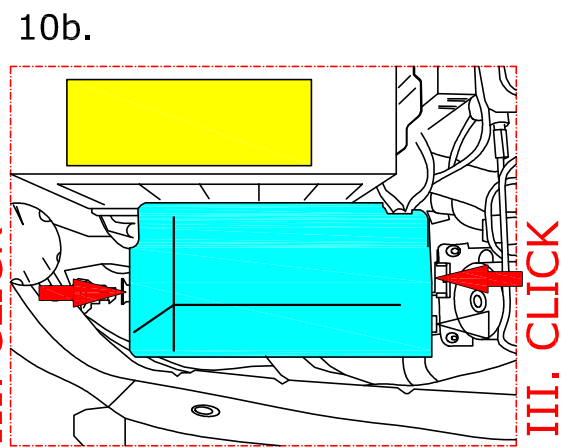
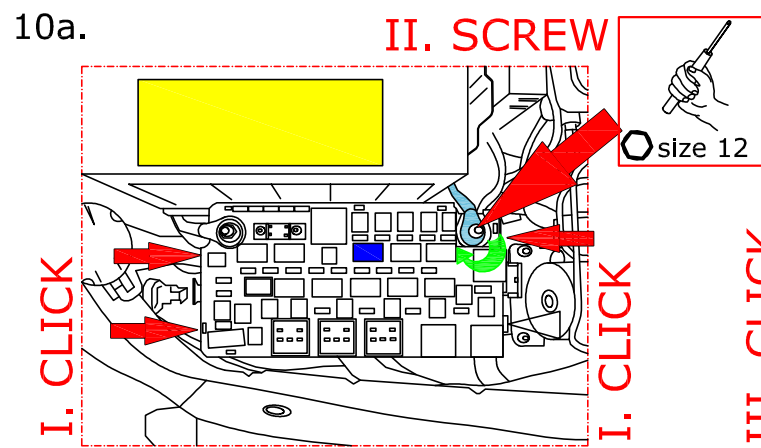
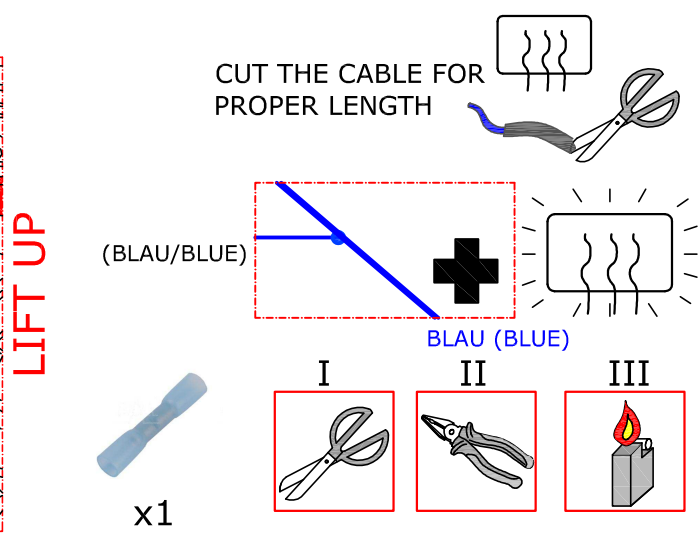
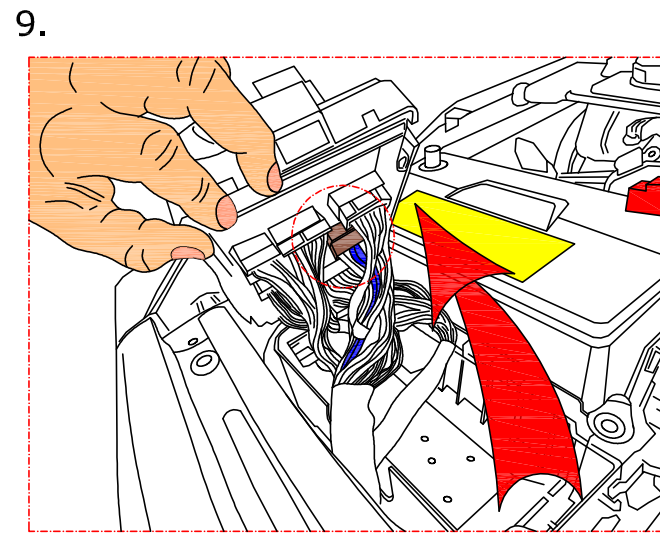
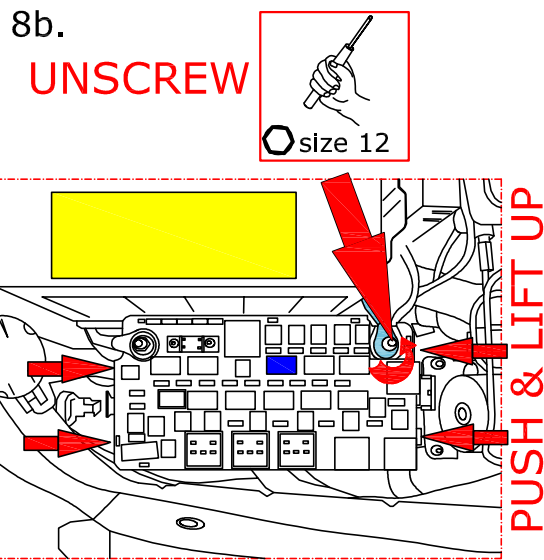
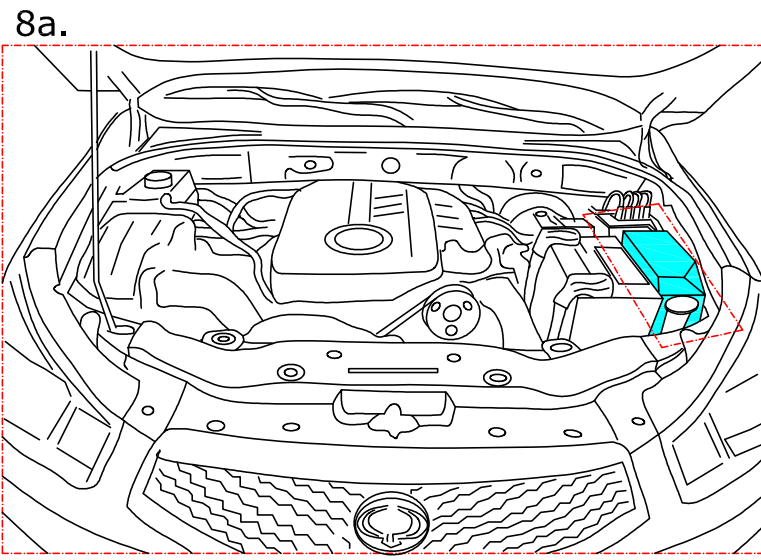

12.

L1

R1

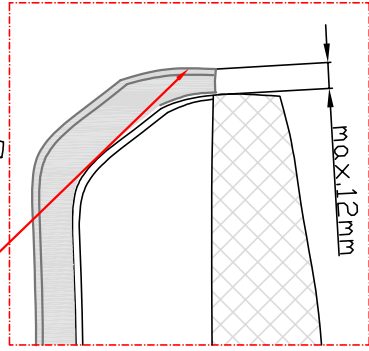
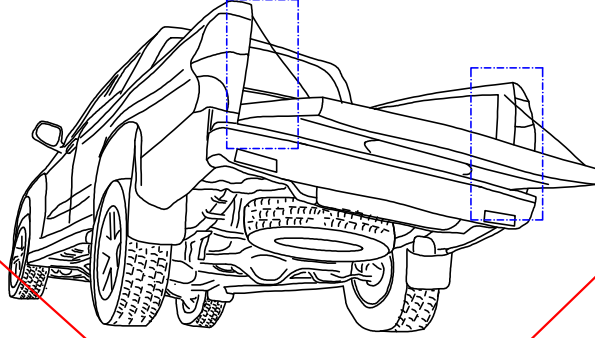
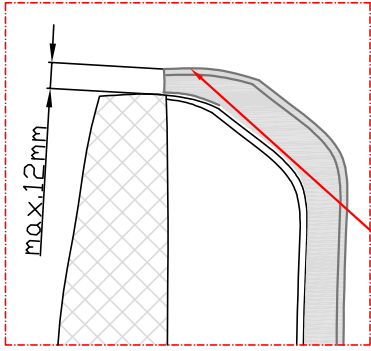
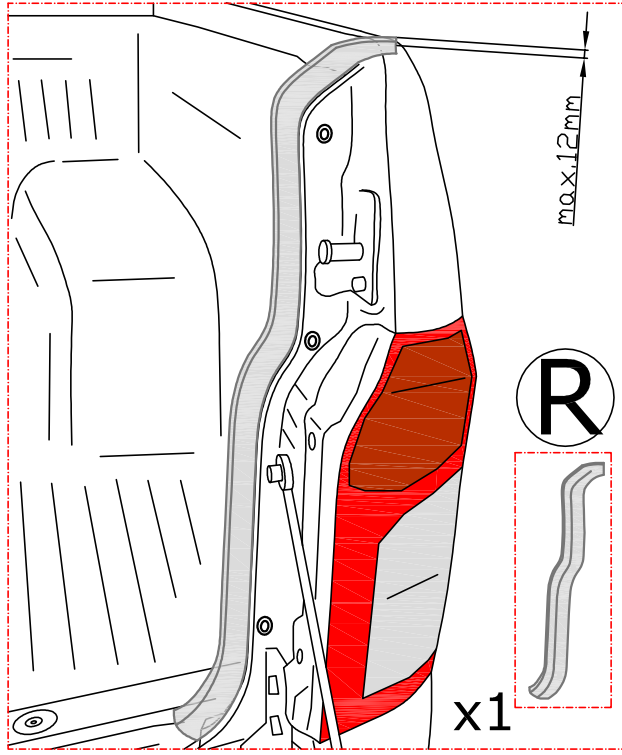
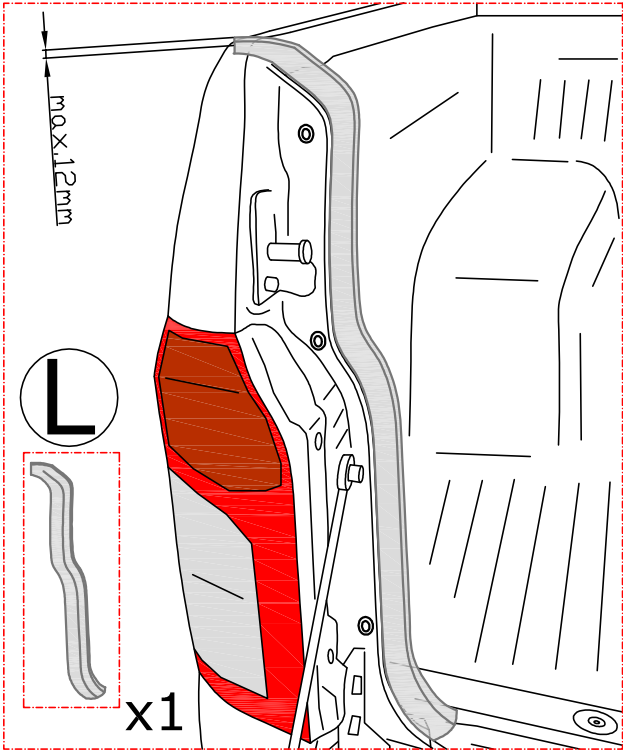

L2

R2

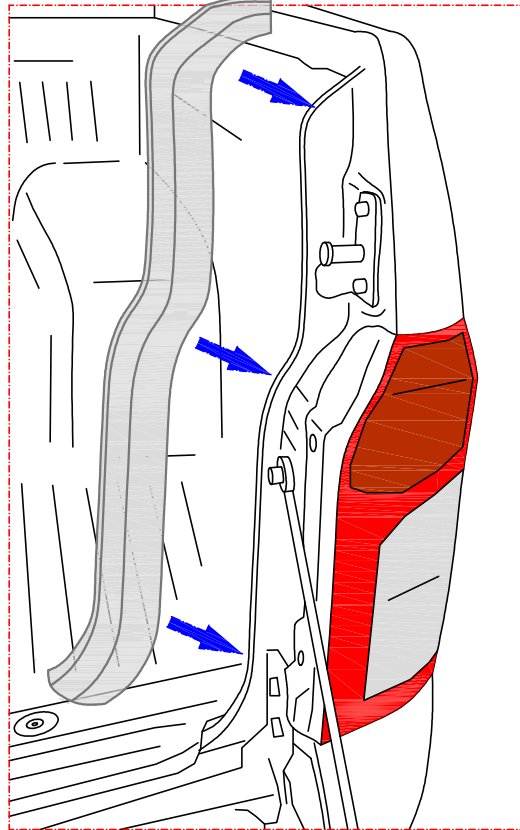
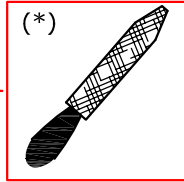
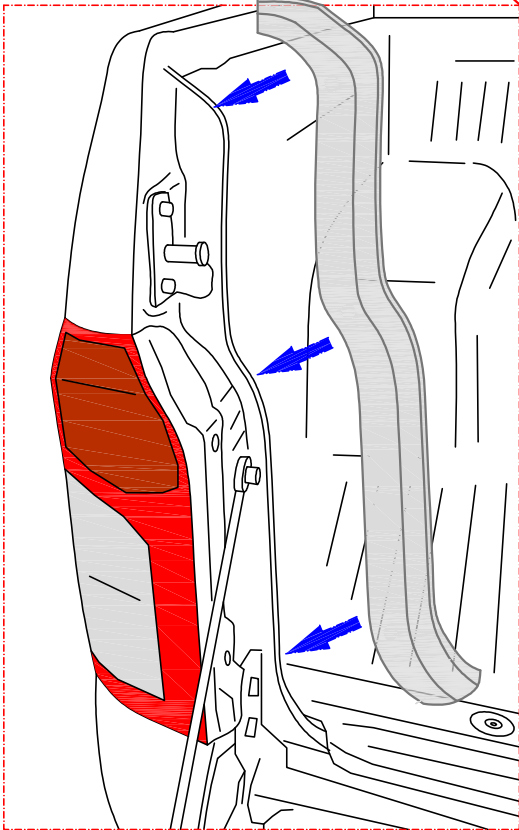

Montageanleitung >> Инструкция по установке >>

Installation instruction >> Instructions de montage >> Istruzioni di montaggio >> Montageanvising >> Instruções de Montagem

Montageanleitung >> Инструкция по установке >>

Installation instruction >> Instrucciones de montaje >> Istruzioni di montaggio >> Montageanvising >> Instruções de Montagem

13.

L3

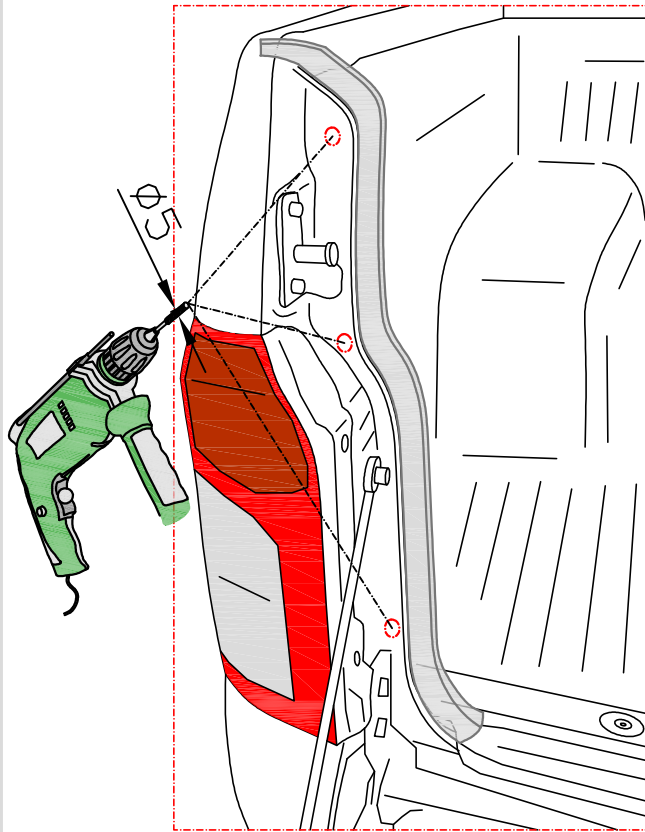

R3

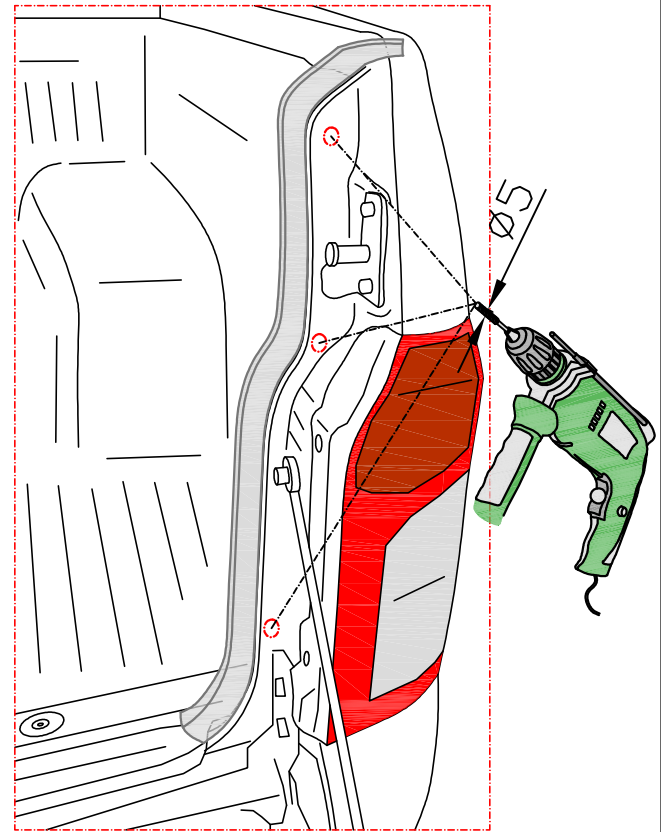

I

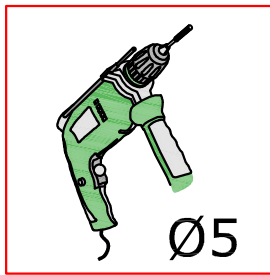

II

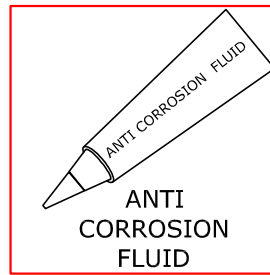

III

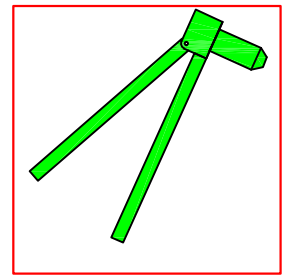

L4

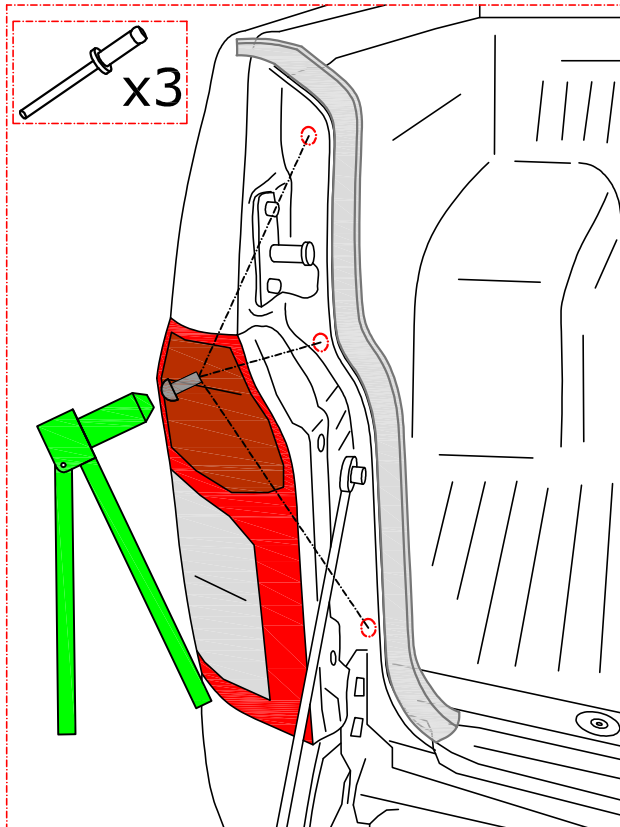

R4

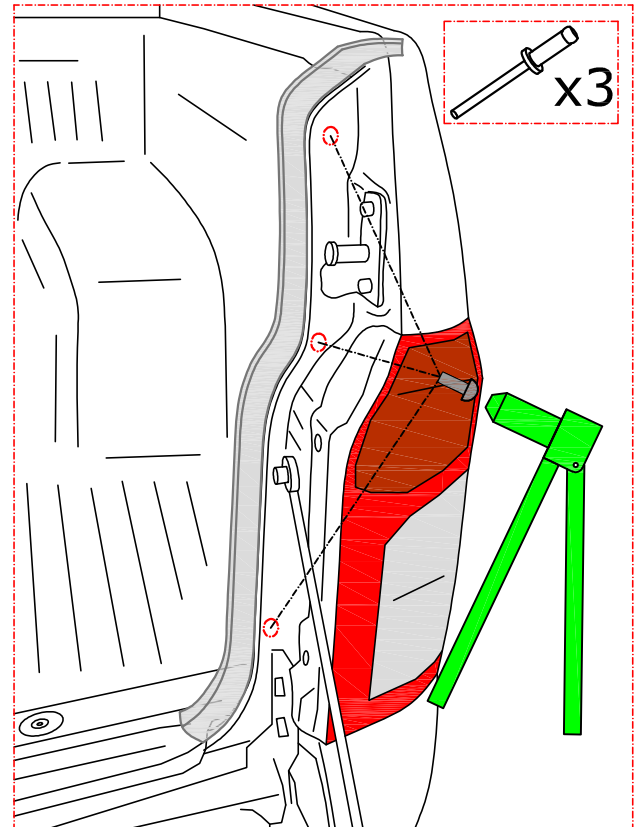

14.

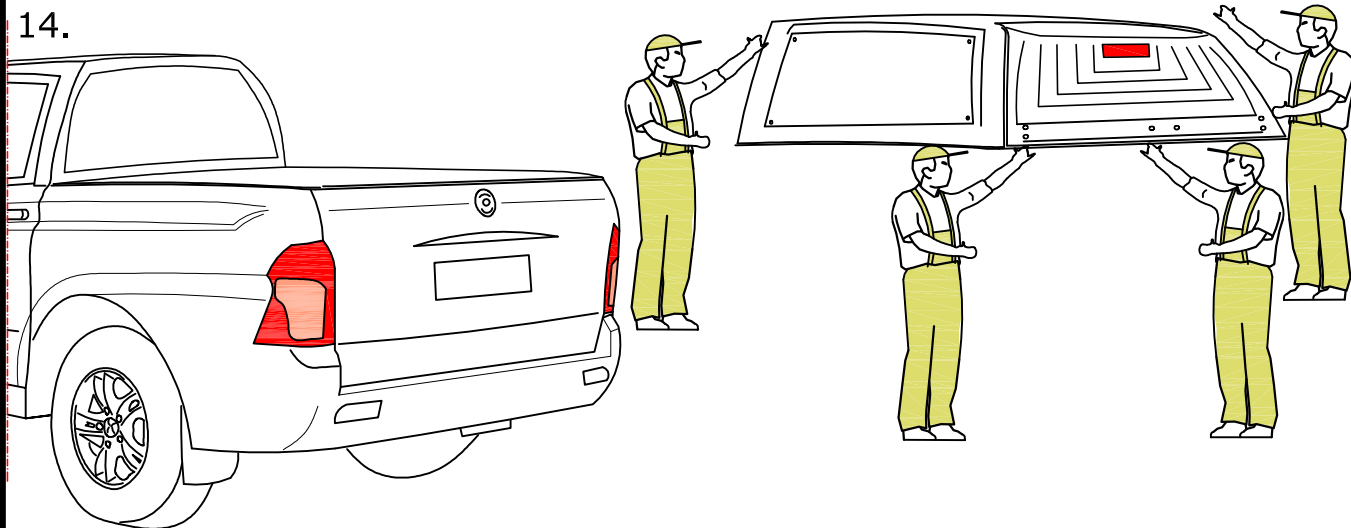

15.

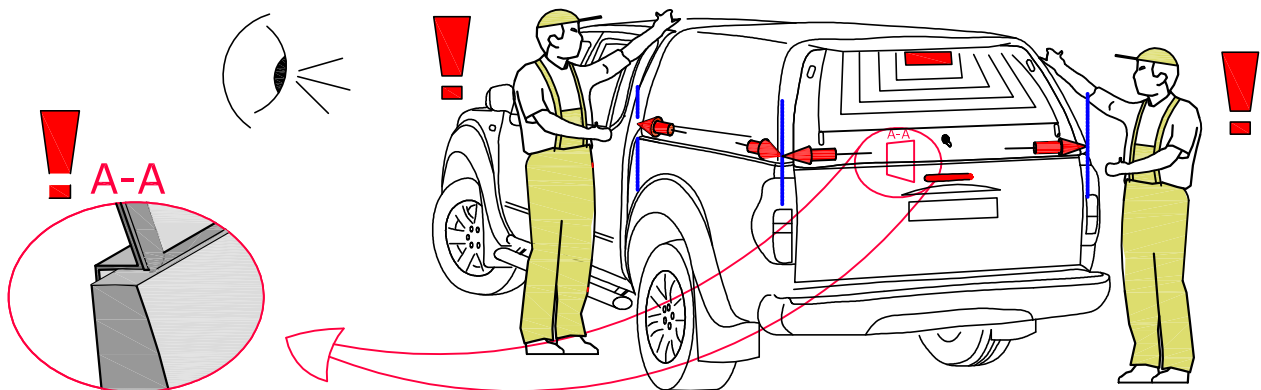

16.

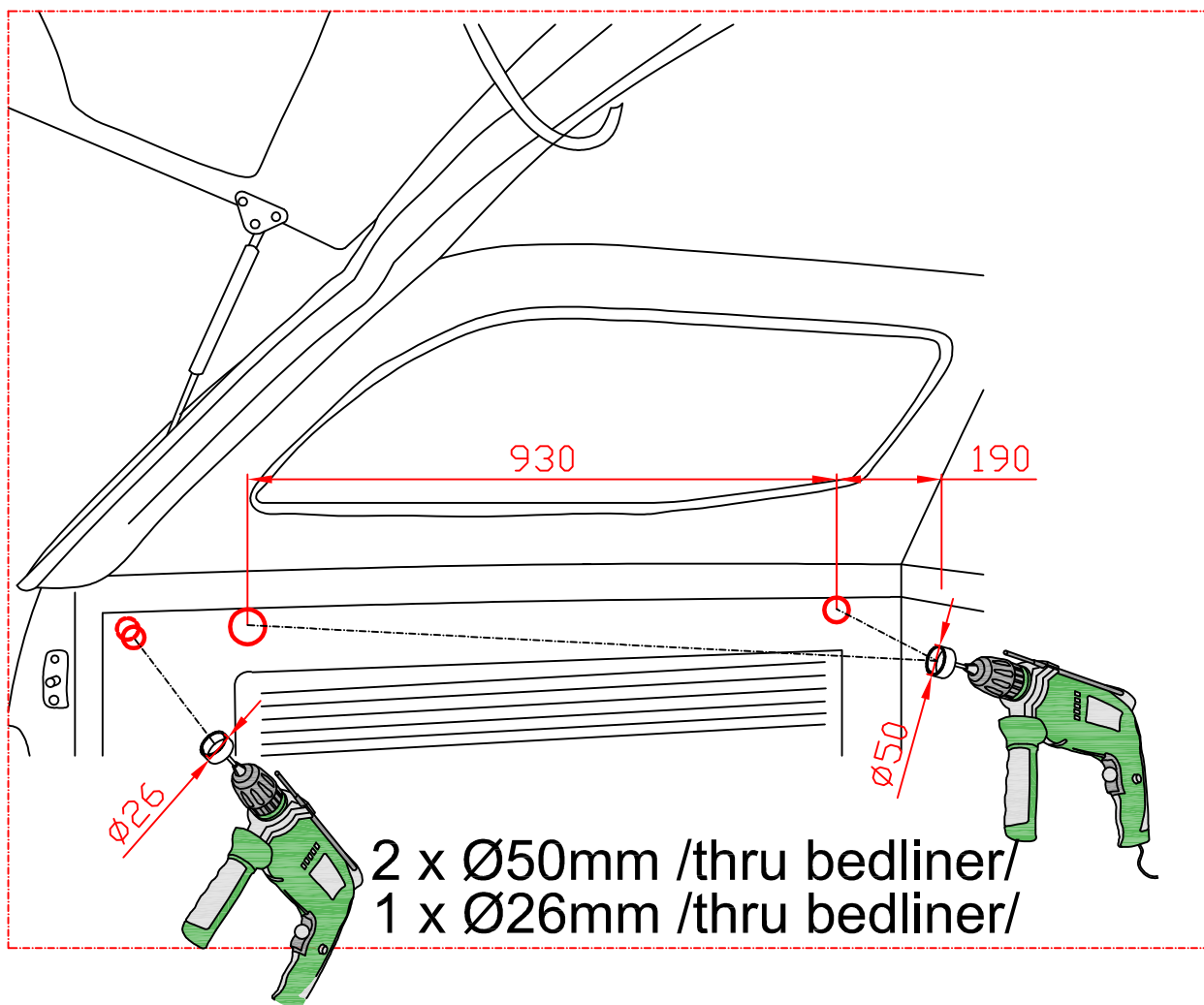

Montageanleitung >> Инструкция по установке >>

Installation instruction >> Instrucciones de montaje >> Istruzioni di montaggio >> Montageanvising >> Instruções de Montagem

17.

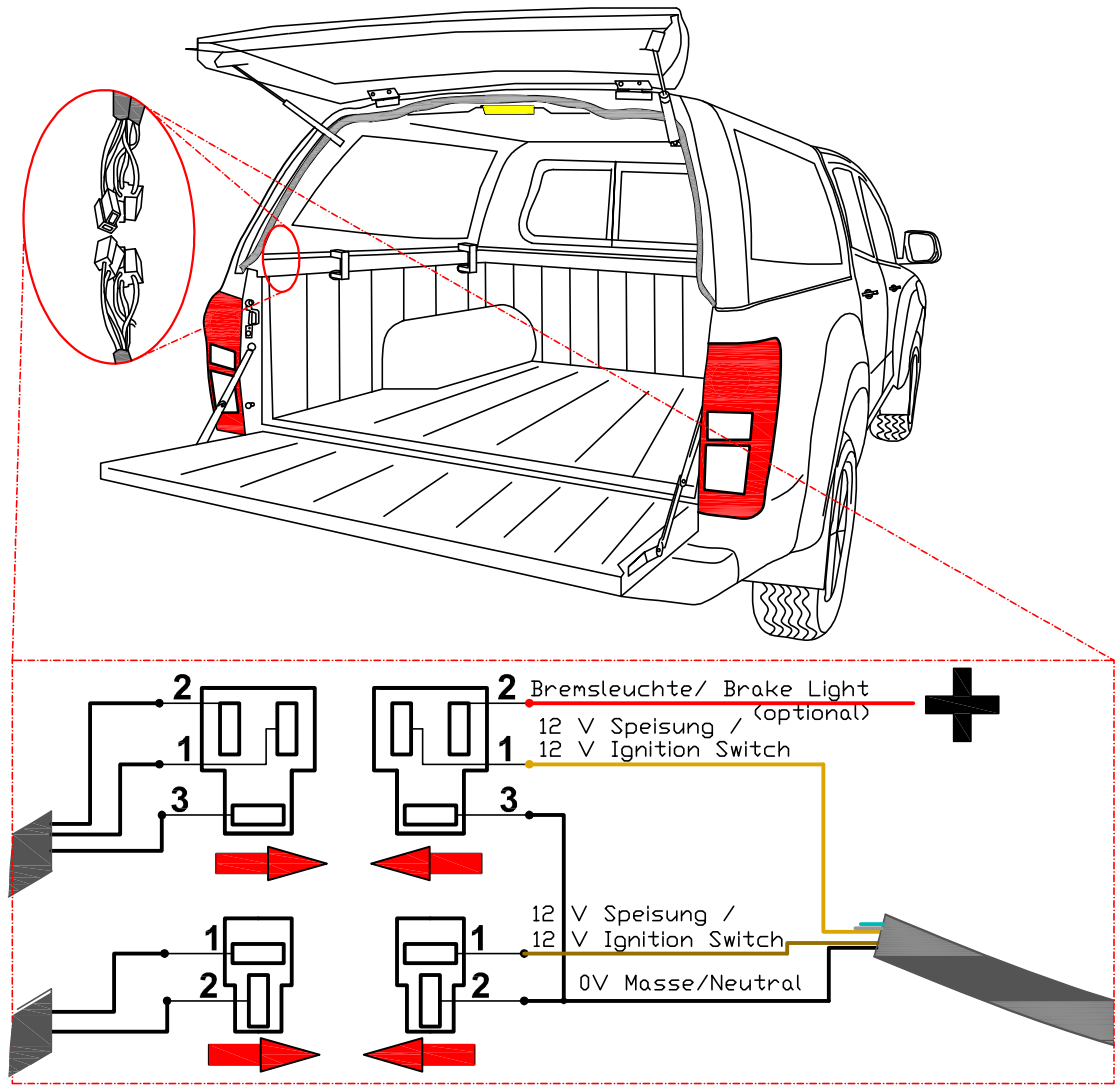

18.

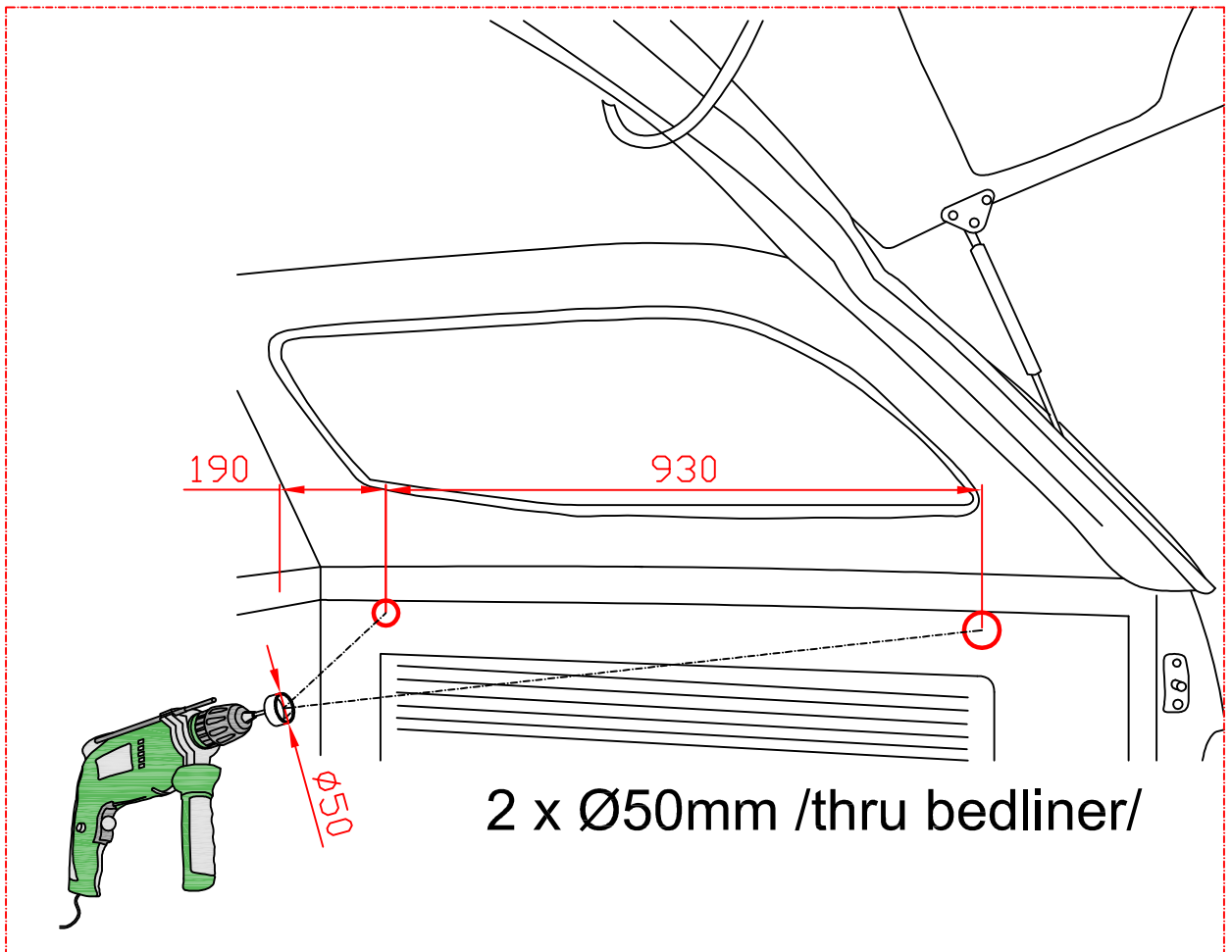

19.

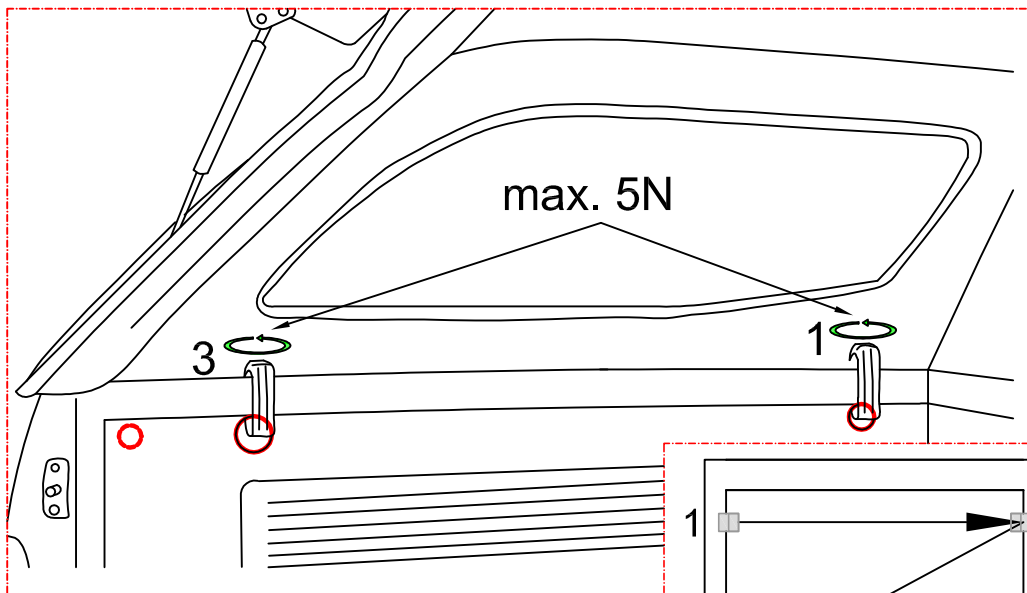
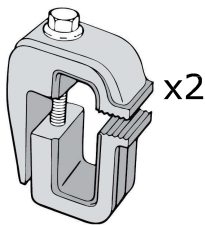

20.

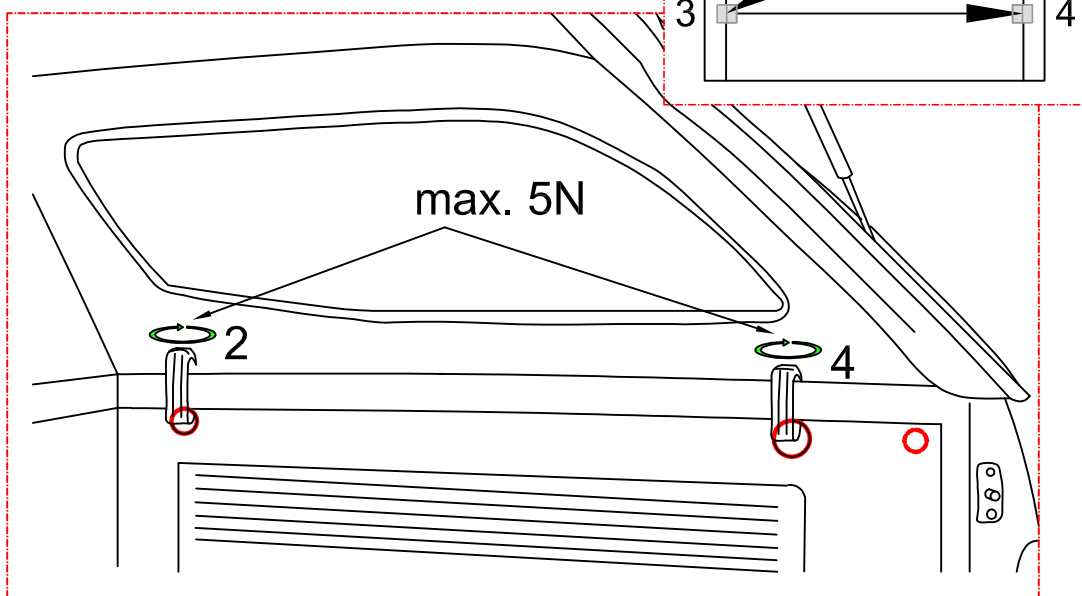
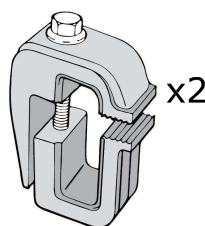
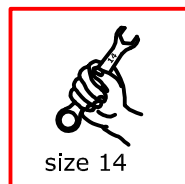

21.

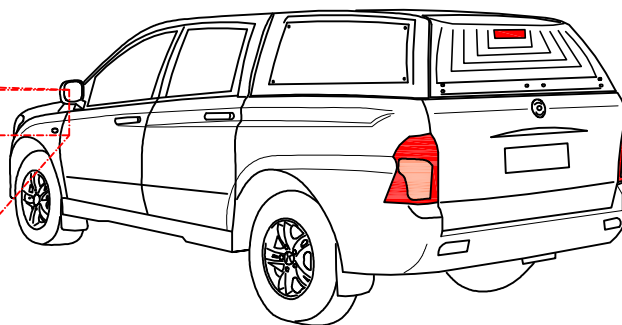
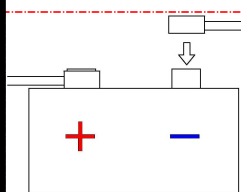

22.

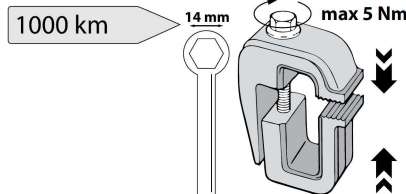
**(D) ACHTUNG!**

Etwaige Gewährleistungsansprüche bzw. Schadensersatzansprüche aller Art können von uns nur bei einer ordnungsgemäßen und der Anleitung entsprechenden Montage in einer Fachwerkstätte berücksichtigt werden.

Wir weisen ausdrücklich darauf hin, daß eine unsachgemäße und nicht in einer Fachwerkstätte durchgeführte Montage einen Verzicht auf die Geltendmachung jeglicher Art insbesondere auch aus dem Titel des Produkthaftpflichtrechtes bewirkt. Für die Befestigung sind ausschließlich die beiliegenden Befestigungsteile zu verwenden.

(F) ATTENTION!

Nous attirons votre attention sur le fait que toute réclamation ou demande en dommage et intérêt ne pourrait être formulée que tant que le montage aura été fait suivant les instructions techniques prévues pour notre produit.

Il est expressément prévu qu' on ne saurait se prévaloir d' un quelconque préjudice contractuel ou rédhibitoire si le montage avait été fait en dépit des dites instructions ou dans un garage ne disposant pas des équipements adéquats. Pour la fixation, utiliser exclusivement les éléments ci-joints.

(RU) ВНИМАНИЕ!

Гарантийные случаи и гарантийные компенсации всех видов возможны только в том случае, если установка производилась компетентными специалистами при строгом соблюдении всех пунктов данной инструкции.

Обратите Ваше внимание на то, что любая неправильная установка а также установка не компетентными специалистами приведет к принудительному отказу от любого вида гарантийных возмещений, что соответствует законодательству. Для установки используйте только те крепежные элементы, которые идут в комплекте поставки.

(S) OBS!

Eventuella garantier och skadeståndskrav av all slag kan endast godkännas om monteringen har genomförts på aut. verkstad enligt monteringsanvisning.

Vi påpekar uttryckligt att en ej lämplig eller ej på verkstad genomförd montering medför förlust av rätten att göra gällande anspråk av alla slag i synnerhet rätten ur produktansvarighets lagen.

För monteringen får endast de bifogade monteringsdestaljerna användas.

(GB) ATTENTION!

Guarantee claims/compensation claims of all kinds can only be entertained by us if assembly has been carried out properly and in accordance with instructions in a specialist workshop.

We would expressly point out that any improper assembly which is not carried out in a specialist workshop will result in the renunciation of the enforcement of compensation claims of any kind, in particular those arising by virtue of the product liability law. For the purpose of fixing, please use the attached fixing parts only.

MKT
Car-Technik

MKT Car-Technik Sp. z o.o.
ul. Spokojna 5
14-100 Ostróda
Poland
Telefon: +48 89-646-13-23
Fax: +48 89-646-13-24
Email: info.mkt@hoehn.pl

DR. HÖHN
Die Formel für Fahrvergnügen
Dr. Höhn GmbH

Künzelsauer Str. 13
74653 Ingelfingen
Germany
Telefon: +49 7940 9202 41
Fax: +49 7940 9202 45
www.hoehn.de
Email: roadranger@hoehn.pl

Montageanleitung >> Инструкция по установке >>

Installation instruction >> Instruções de montagem >> Montageanvisning >> Istruzioni di montaggio >> Instrucciones de montaje >> Instruções de montagem

Montageanleitung >> Инструкция по установке >>

Installation instruction >> Istruzioni di montaggio >> Instrucciones de montaje >> Montageanvising >> Instruções de Montagem

SSANG YONG SY DC RH01 3

Heizbare Scheibe ; LED Beleuchtung

Bremsleuchte / 3rd Brake Light

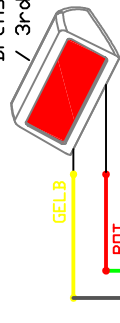

Innenleuchte / Interior light

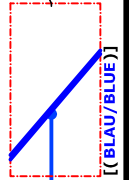
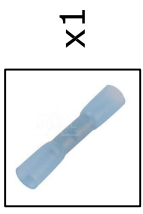
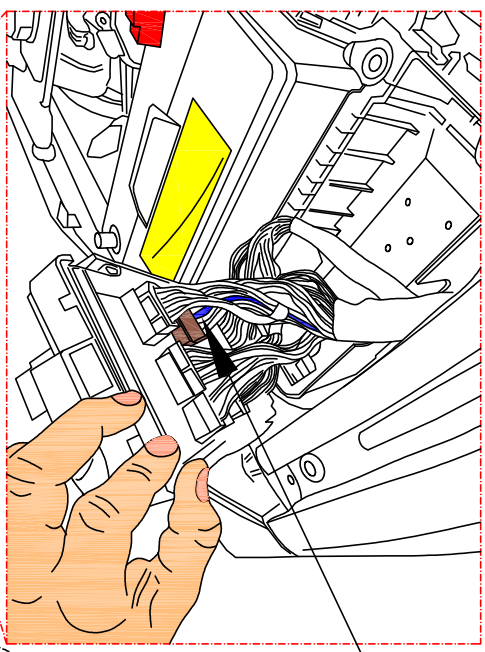
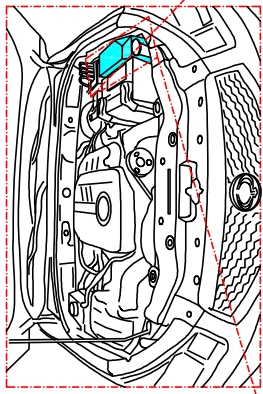
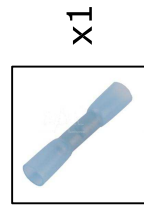
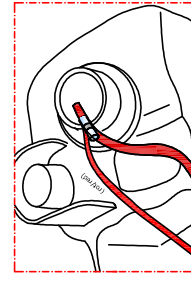
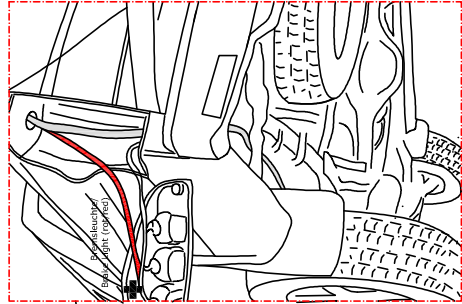
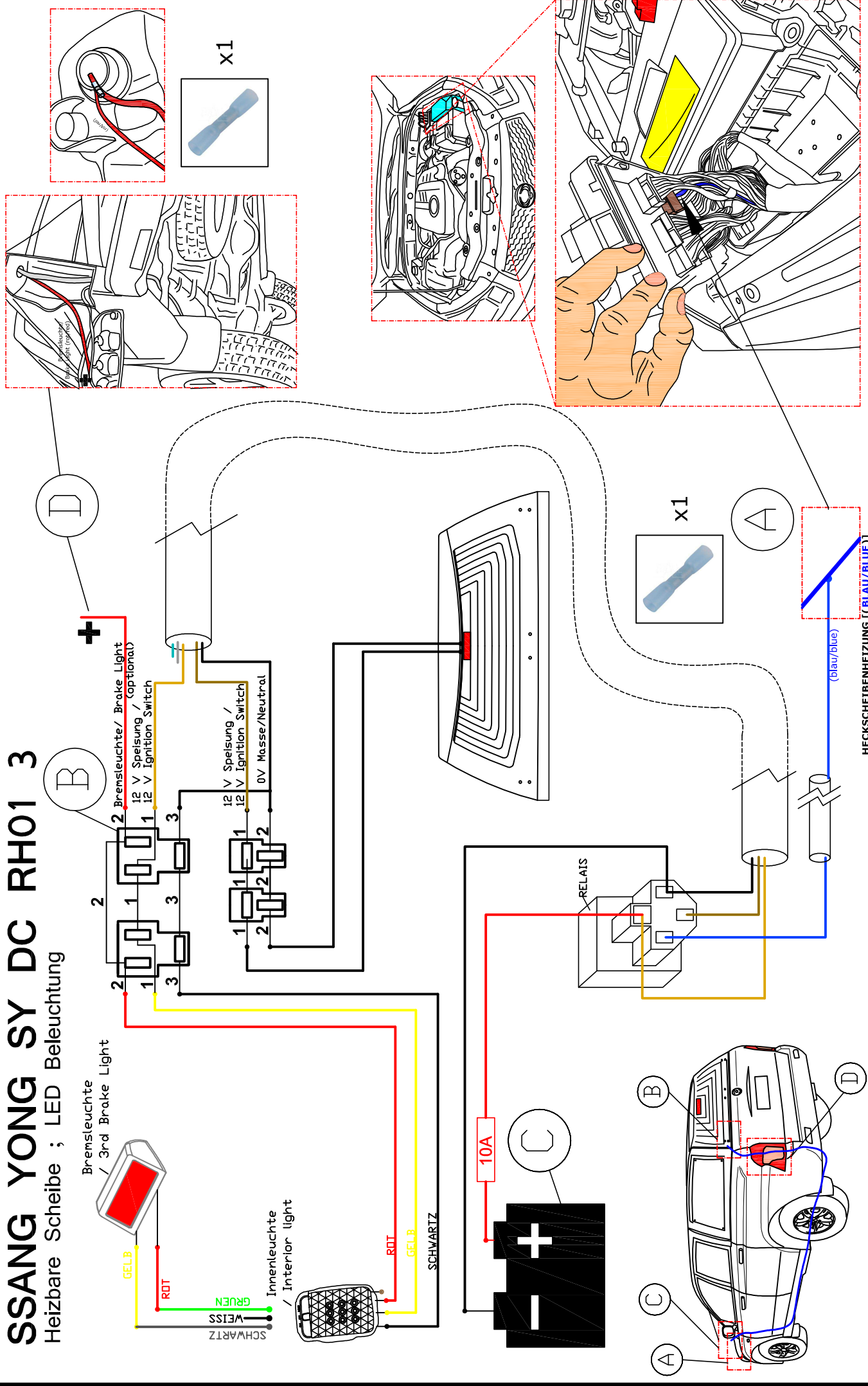

HECKSCHHEIBENHEIZUNG [(BLAU/BLUE)]